



## Device User Manual

**Econo 328 / FIO Controller 328**  
Embedded Compact PC/PLC

E 868 EN

13.02.2026

# Table of Contents

1 Foreword .....	5
1.1 Imprint.....	5
1.1.1 Release Information .....	5
1.2 About this guide .....	5
1.2.1 Limitations of Liability .....	5
1.2.2 Terms of delivery .....	5
1.2.3 Urheberrecht / Copyright.....	6
1.2.4 Licenses .....	6
1.2.5 Warranty Policy .....	6
1.3 Reliability, safety.....	7
1.3.1 Scope .....	7
1.3.2 Responsibility of the Project Engineer and Operator .....	7
1.3.3 Target group of the user manual.....	7
1.3.4 Intended use.....	7
1.3.5 Hazard and warning statements .....	8
1.3.6 Other notes.....	8
1.3.7 Electrical safety .....	9
1.3.8 IT security .....	10
1.3.9 CODESYS Security.....	10
1.3.10 Disclosure of security vulnerabilities .....	10
1.3.11 Electromagnetic compatibility.....	11
1.4 Quality and environmental management.....	13
1.4.1 Reliability .....	13
1.4.2 Disposal and recycling .....	13
1.4.3 Notes on the REACH Regulation and SVHC Information .....	13
2 System description .....	14
2.1 Econo 328.....	14
2.2 Modular CODESYS controller, FIO controller 328 .....	14
2.2.1 CODESYS.....	15
2.2.2 CODESYS Building Blocks .....	15
3 Product Description .....	17
3.1 General description .....	17
3.2 Front view Econo / FIO Controller 228 .....	18
3.3 Front view Econo / FIO Controller328 .....	18
3.4 Component Categorization.....	18
3.5 Application area .....	18
3.5.1 Intended Use .....	19
3.5.2 Terms of Use.....	19
3.5.3 Foreseeable misuse.....	19
3.5.4 Disclaimer.....	20
3.6 Technical data .....	21
3.6.1 General device data FIO Controller 328 / Econo 328 .....	21
3.6.2 Device Data PROFINET IO Device Extension.....	23
3.6.3 Device Data EtherCAT Device Extension.....	23
3.6.4 Device Data Ethernet Expansion .....	23
3.6.5 Device Data LAN/CAN/RS-485 Extension .....	23
4 Structure and function .....	24
4.1 Short description.....	24

4.2	Product Identification .....	25
4.2.1	Device Information .....	25
4.2.2	Serial Number .....	26
4.3	Scope of Delivery .....	27
4.2	Transport and storage .....	28
4.2.1	Transport inspection.....	28
4.2.2	Packaging.....	28
4.3	Connector Overview .....	29
4.3.1	Graphics Interface "HDMI", (X1) .....	32
4.3.2	"USB 2.0" (X2).....	32
4.3.3	"EtherCAT Out" (X3)- Version FIO Controller .....	33
4.3.4	Ethernet "LAN 0" (X3) in the Econo version .....	34
4.3.5	"USB" USB 3.2 Gen1 (X4, X5).....	34
4.3.6	Ethernet "LAN 1.1" (X6), LAN 1.2 (X7) (switched).....	35
4.3.7	Expansion Interfaces.....	37
4.3.8	Power supply "24 VDC" (X10).....	38
4.3.10	Functional Earth "X11" .....	39
4.3.11	µSD(HC)-Card Slot .....	40
4.3.12	Retain Variablen.....	42
4.3.13	Real Time Clock (RTC) .....	42
4.4	Displays and Controls.....	43
4.4.1	Status Indicators (FIO Controller Version) .....	43
4.4.1	Status Indicators (Econo Version).....	43
4.5.1	Start / Stop -Taster "Start / Stop" .....	45
4.6	Accessories and Tools .....	46
4.6.1	Fans with EMC shield terminals.....	46
5	Installation and operation .....	48
5.1	Installation Environment .....	48
5.2	Mechanical installation .....	48
5.2.1	Mounting.....	48
5.3	Electrical installation .....	51
5.3.1	Functional Earth .....	51
5.3.2	Connection to the FIO Modules .....	51
5.3.3	System supply .....	52
5.3.4	EtherCAT.....	53
5.3.5	Modbus TCP .....	53
5.3.6	Connecting Screens and Touch.....	53
5.4	Initial commissioning .....	54
5.4.1	General information on commissioning.....	54
5.4.2	Prerequisites for Commissioning .....	54
5.4.3	Turn on the device .....	54
5.4.4	Turn off the device .....	54
5.5	Configuration .....	55
5.5.1	Webinterface .....	55
5.6	Diagnosis .....	56
5.6.1	Ads .....	56
5.6.2	Fault table.....	56
5.7	Maintenance / Repair .....	57
5.7.1	General.....	57
5.7.2	Maintenance.....	57

5.7.3 Maintenance .....	57
5.8 Lifespan .....	57
5.8.1 Repairs / After-sales Service .....	57
5.8.2 Warranty .....	57
5.8.3 Decommissioning .....	57
5.8.4 Disposal .....	57
6 Specific Device Functions .....	59
6.1 System Information .....	59
6.2 Undervoltage detection .....	59
6.3 Mini USV .....	59
6.4 Memory usage .....	59
6.5 Temperature sensor .....	60
6.6 Expansion via USB adapter .....	61
6.7 USB Update Functions .....	62
6.8 Device Description .....	62
7 Appendix .....	63
7.1 Dimensions .....	63
7.1.1 Controller / Econo .....	63
7.1.2 Controller / Econo with fan and EMC terminals .....	64
7.2 Standards and limit values complied with .....	65
7.2.1 Safety-related standards and guidelines .....	65
7.2.2 Cyber Security .....	65
7.2.3 EMV .....	65
7.2.4 Material Compliance .....	65
7.2.5 Permissible environmental conditions .....	65
7.3 Policies and Statements .....	67
7.3.1 Conformity marking .....	67
7.3.2 RoHS .....	67
7.4 Approvals .....	67
7.5 Ordering details .....	68
7.5.1 Basic Units .....	68
7.5.2 Basic Devices .....	69
7.5.3 Accessories .....	70

# 1 Foreword

## 1.1 Imprint

### Contact Details

Kendrion Kuhnke Automation GmbH  
 Industrial Control Systems  
 Lütjenburger Straße 101  
 D-23714 Malente  
 Germany

Tel. Support           +49 4523 402-300  
 E-Mail-Support       [controltechnology-ics@kendrion.com](mailto:controltechnology-ics@kendrion.com)  
 Tel.                     +49 4523 402-0  
 Headquarters  
 Email Sales           [sales-ics@kendrion.com](mailto:sales-ics@kendrion.com)  
 Internet               [www.kendrion.com](http://www.kendrion.com)  
 Vulnerability         [psirt@kendrion.com](mailto:psirt@kendrion.com)  
 Reports

### 1.1.1 Release Information

#### Manual history

Date	Comments / Changes
17.02.2023	Original version

## 1.2 About this guide

This technical information is intended for specialists in the fields of design, design and machine and apparatus development. It does not contain any information on delivery options. Changes and errors are reserved. The illustrations shown are for illustrative purposes only and may differ from the actual product.

### 1.2.1 Limitations of Liability

The data provided are for product description purposes only and are not to be understood as a guaranteed quality of the product in the legal sense. Quality agreements are reserved for the specific contractual relationship. Any claims for damages against us – regardless of the legal basis – are excluded, unless we are guilty of intent or gross negligence

### 1.2.2 Terms of delivery

The general terms and conditions of sale and performance of Kendrion Kuhnke Automation GmbH apply.

## 1.2.3 Urheberrecht / Copyright

© Kendrion Kuhnke Automation GmbH

This instruction manual is protected by copyright.

Reproduction and duplication in any kind and form, in whole or in part, is not permitted without the written permission of Kendrion Kuhnke Automation GmbH .

Microsoft®, Windows®, and the Windows® logo are registered trademarks of Microsoft Corp. in the U.S. and other countries.

EtherCAT® is a registered trademark and patented technology licensed by Beckhoff Automation GmbH, Germany.

See [www.plcopen.org](http://www.plcopen.org) for more information about the PLCopen organization. CiA® and CANopen® are registered Community trademarks of CAN in Automation e.V.

CODESYS® is a product of CODESYS GmbH.

ARM ® and Cortex ® are registered trademarks of ARM Limited.

PROFINET® is a registered trademark of the PROFIBUS user organization e. V.

Modbus® is a registered trademark of the Modbus-IDA organization.

Raspberry Pi is a registered trademark of the Raspberry Pi Foundation

The terms HDMI, HDMI High-Definition Multimedia Interface, HDMI Trade Dress and the HDMI logos are trademarks or registered trademarks of HDMI Licensing Administrator, Inc.

The rights of all companies and company names as well as goods and trade names mentioned here belong to the respective companies.

## 1.2.4 Licenses

### Firmware

The firmware of the devices contains open source software.

A list of the packages used and the corresponding licenses can be found on the device in the web interface under the menu item Home/Packages and Licenses.

The source code of the free software can be requested from the support Kendrion Kuhnke at cost price within three years of delivery of the device.

### CODESYS

The installed CODESYS Runtime, like all CODESYS products, is subject to the terms of the End User License Agreement (EULA) of CODESYS GmbH, which can be viewed on the CODESYS website.

## 1.2.5 Warranty Policy

With regard to the warranty, reference is made to the provisions of the terms and conditions of sale of Kendrion Kuhnke Automation GmbH or, if available, to the existing contractual agreements.

## 1.3 Reliability, safety

### 1.3.1 Scope of application

This instruction manual contains information that you must observe for your personal safety and to avoid property damage when working with the Kendrion Kuhnke product.

### 1.3.2 Responsibility of the designer and operator

The operator's responsibility for a technical device is to use the manual properly and to follow the instructions and safety guidelines contained therein. This is critical to ensuring user safety, enabling flawless device operation, and ensuring regulatory compliance.

Exemplary points:

- Intended use of the device
- The documentation must be available and accessible.
- Only sufficiently qualified and authorized personnel may assemble, install, commission and maintain the device.
- Ensure compliance with the instructions in the manual.
- The national and international regulations for the control of machines and systems must be observed.

### 1.3.3 Target group of the user manual

This user manual contains the necessary information for the intended use of the described product (control unit, control terminal, software, etc.). It is aimed at specialist personnel from design, project planning, service and commissioning. Comprehensive knowledge of automation technology is required for the correct understanding and error-free implementation of technical descriptions, operating information and, in particular, hazard and warning information.

### 1.3.4 Intended use

Kendrion Kuhnke products have been designed, developed and manufactured for ordinary industrial use. and may only be used for the applications provided for in the catalogue and in the associated technical documentation. The flawless and safe operation of the products requires proper transport, proper storage, installation, assembly, installation, commissioning, operation and maintenance. The permissible environmental conditions must be observed. Notes in the associated documentation must be observed.

### 1.3.5 Hazard and warning information

Despite the fact that the 1.3 Reliability, safety In accordance with the measures described, the occurrence of errors in electronic control systems must be expected, no matter how unlikely they may be.

Please pay special attention to the additional instructions that we have marked with symbols in this manual. Some of these hints draw attention to dangers, others serve more as orientation for the reader. In order of decreasing importance, they are described below.

The content in the hazard and warning information is structured as follows:

**Type and source of danger**

*Possible consequences of non-compliance*

⇒ Measures to prevent

	<p><b>DANGER</b></p> <p><i>The notice with DANGER refers to an immediately dangerous situation which, if the notice is disregarded, will inevitably lead to a serious or fatal accident.</i></p>
	<p><b>WARNING</b></p> <p><i>The WARNING note refers to a potentially dangerous situation that failure to comply with the advice could lead to a serious or fatal accident or damage to this device or other devices.</i></p>
	<p><b>CAUTION</b></p> <p><i>The note CAUTION refers to a potentially dangerous situation that if the advice is disregarded, it may lead to an accident or may cause damage to this device or other equipment.</i></p>
	<p><b>NOTE</b></p> <p><i>This notice refers to a potentially dangerous situation that, if disregarded, may result in damage to this device or other equipment.</i></p>

### 1.3.6 Other notes

	<p><b>Information</b></p> <p><i>This mark draws attention to additional information concerning the use of the product described. It can also be a cross-reference to information found elsewhere (e.g. in other manuals).</i></p>
--	---

### 1.3.7 Electrical safety

Our products usually become part of larger systems or plants. The following tips are intended to help integrate the product into the environment without danger to people and machines/systems.

	<b>DANGER</b>
	<p><b><i>Disregard for the operating instructions</i></b></p> <p><i>Precautions to prevent dangerous errors can be overridden or additional sources of danger can be created.</i></p> <ul style="list-style-type: none"> <li>⇒ <i>Read the operating instructions carefully</i></li> <li>⇒ <i>Pay special attention to hazard warnings</i></li> </ul>

	<b>Information</b>
	<p><i>In order to achieve the highest level of conceptual safety when designing and installing an electronic control unit, it is essential to follow the instructions contained in the operating instructions exactly, as incorrect handling may override precautions to prevent dangerous errors or create additional sources of danger.</i></p>

#### When planning a project , consider

- In the event of power failures or dips: the program must be set up in such a way that a defined state is established during restart, which excludes dangerous conditions.
- The safety and accident prevention regulations applicable to the specific incident must be observed.
- Please pay particular attention to the hazard warnings, which are intended to draw attention to possible sources of error at the appropriate point.
- In any case, the relevant standards and VDE regulations must be complied with.
- Install controls in such a way that unintentional actuation is excluded.
- Route control cables in such a way that there are no interferences (inductive or capacitive) that could affect the function of the control unit.

#### Observe during servicing or servicing

- When measuring and testing the control unit is switched on, the accident prevention regulation BGV A3 (Electrical systems and equipment must be observed), in particular §8 (Permissible deviations when working on parts).
- Spare parts: Use only those spare parts that are approved by Kendrion Kuhnke. Only Kendrion Kuhnke original modules may be used in the modular control units.
- For modular systems: Modules may only be plugged in or removed from the control system when there is no voltage. Otherwise, they can be destroyed or their function (possibly not immediately recognizable!) impaired.
- Batteries and accumulators, if available, should only be disposed of as hazardous waste.

### 1.3.8 IT Security

Kendrion Kuhnke products are designed to operate within closed industrial networks.

If the industrial networks are publicly accessible, e.g. through freely accessible network interfaces, or publicly accessible, e.g. through data connections via public data traffic (Internet), then the integrator and operator must take appropriate organisational and technical security measures to protect the internal network and ensure IT security.

	<p><b>Information</b></p> <p><i>Information for the safe operation of plants, systems, machines and networks can be found in the information brochures of the BSI and IEC 62443, among others.</i></p>
---	--

### 1.3.9 CODESYS Security

Automation devices contain functional units that are worth protecting. This includes classic control and regulation functions and algorithms, but also production data of the system users. Since no automation solution is error-free, there are potential, risky vulnerabilities.

A threat exists mainly via LAN networks, but attacks via local interfaces are also possible.

The following attack paths must be considered:

- Interfaces (USB, LAN, Fieldbus, .....
- Services, drivers, protocols (RPC, HTTP(S)...) )
- Authentication, encryption (force login, encrypt PW)
- Physical access (locked rooms, cupboards)
- External systems, external employees

As much as possible, avoid exposing the PLC and control networks to open networks and the Internet. For protection, use additional layers of security such as a VPN (Virtual Private Network) for remote access and install firewall mechanisms. In principle, all unnecessary interfaces and services should be deactivated or access restricted. Effective protection of automation devices can also be carried out via segmentation, e.g. routers with firewalls.

	<p><b>NOTE</b></p> <p><b><i>Third-party access to the computer</i></b>  <i>Control failure and data loss</i></p> <p>⇒ When integrating into publicly accessible networks, the user must take appropriate measures to prevent unauthorized access.</p>
---	---

	<p><b>NOTE</b></p> <p><b><i>Please note the security information issued by CODESYS and continuously updated at:</i></b>  <a href="https://www.codesys.com/security"><b><i>https://www.codesys.com/security</i></b></a></p>
---	--

### 1.3.10 Disclosure of security vulnerabilities

#### Coordinated Vulnerability Disclosure Policy

At Kendrion Kuhnke, the security and integrity of our embedded devices and software solutions are our top priority. We value the important role of independent security researchers and our community in maintaining high security standards. We encourage you to responsibly report any security vulnerabilities discovered in our products or services. Further information can be found on our website:

[Cyber Security at Kendrion | Collaboration for the highest level of security](#)

## How to report a vulnerability

To report a security vulnerability, send an email to [psirt@kendrion.com](mailto:psirt@kendrion.com). For secure communication, please use PGP-encrypted e-mails. More details and the PGP public key can be found here:

[Cyber Security at Kendrion | Collaboration for the highest level of security](#)

An alternative course of action, if at any time Kendrion's services are unavailable, is to contact VDE Cert directly by e-mail [info@cert.vde.com](mailto:info@cert.vde.com) or via the contact form:

[CERT@VDE](mailto:CERT@VDE).



## Published safety advisories

For transparency reasons and to help the community, we keep a log of all fixed security vulnerabilities. These records can be crucial for users and researchers alike to understand the nature of the vulnerabilities and their solutions. Access our library of published safety advisories at <https://cert.vde.com/de/advisories/vendor/kendrion/>.

We reserve the right to change this policy as necessary.

## 1.3.11 Electromagnetic compatibility

### Definition

Electromagnetic compatibility is the ability of a device to operate satisfactorily in the electromagnetic environment without itself causing electromagnetic interference that would be unacceptable to other equipment present in that environment.

Of all known electromagnetic interference phenomena, only a corresponding part of interference occurs depending on the location of a device in question. These faults are specified in the relevant product standards.

The IEC 61131-2 standard, which has been implemented at European level in the EN 61131-2 standard, applies internationally for the design and immunity of programmable logic controllers.

	<p><b>Information</b></p> <p><i>General installation regulations that must be followed in order to limit coupling factors and consequently interference voltages to levels that can be withstood are contained in IEC 61131-4, Guide for Users.</i></p>
--	---

### Disturbance emission

Emission of electromagnetic fields, HF  
according to EN 55011, limit class A, group 1

	<p><b>Information</b></p> <p><i>If the control unit is to be used in residential areas, the limit value class B according to EN 55011 must be complied with with regard to interference emission. This can be achieved by installing the control system in grounded metal cabinets and by installing filters in the supply lines.</i></p>
--	---

### General Installation Instructions

Electronic control systems as part of machines, plants and systems require the consideration of applicable rules and regulations, depending on the area of application.

General requirements for the electrical equipment of machinery with the aim of machine safety are contained in the EN 60204 Part 1 standard (equivalent to VDE 0113).

## Protection against external electrical influences

If provided, connect the control system to the protective conductor to dissipate electromagnetic interference. Ensure favorable cable routing.

### Cable routing

Separate installation of power circuits, not together with control circuits:

- DC voltage                    60 V ... 400 V
- AC voltage                    25 V ... 400 V

Joint laying of control circuits possible:

- Data signals, shielded
- Encoder signals, shielded
- Analogue signals, shielded
- Digital I/O lines, unshielded
- DC voltages < 60 V, unshielded
- AC voltage < 25 V, unshielded

### Installation Location

Make sure that there are no impairments in terms of temperature, impurities, shock, vibration and electromagnetic influence.

### Temperature

Attention to heat sources, such as room heating, solar radiation, heat accumulation in assembly rooms and control cabinets.

### Impurities

Use of appropriate housings to avoid possible adverse effects from moisture, corrosive gases, liquids and conductive dust.

### Shock and vibration

Consideration of possible influences by engines, compressors, transfer lines, presses, pile drivers and vehicles.

### Electromagnetic influence

Attention to electromagnetic interference from various sources on site: motors, switching devices, switching thyristors, radio-controlled devices, welding equipment, electric arcs, switching power supplies, power converters/inverters.

### Special sources of interference

#### Inductive Actuators

When inductors (e.g. relay coils, contactors, solenoid valves and actuator solenoids) are switched off, overvoltages occur. It is necessary to dampen these interference voltages to a permissible level. Damping elements can be diodes, Z-diodes, varistors and RC elements. For the appropriate dimensioning, the technical specifications of the manufacturer or supplier of the actuators must be observed.

## 1.4 Quality and environmental management

### 1.4.1 Reliability

The reliability of Kendrion KUHNKE products is maximized through extensive development and manufacturing efforts. These include the selection of high-quality components, binding quality agreements with suppliers, computer-aided testing of all assemblies and their interaction in the circuit. This is complemented by the statistical evaluation of manufacturing quality and returns in order to initiate immediate corrective measures if necessary.

### 1.4.2 Disposal and recycling

Kontron's products are manufactured with environmental standards in mind, with many of the components used being recyclable. The final disposal of this product at the end of its useful life is subject to applicable national, state, or local laws and regulations. Further information on environmentally friendly disposal and recycling can be found in this guide under the points Decommissioning and disposal.

### 1.4.3 Information on the REACH Regulation and SVHC Information

In accordance with Article 33 of the REACH Regulation, we would like to inform you that SVHC substances may be contained in certain components in a concentration of more than 0.1% (% by weight). These substances are necessary for the functionality or manufacturing processes of the product. We would like to point out that the substances used in this product do not pose any risks to health or the environment under normal use.

#### Note on the SKIP database

Information about the substances of very high concern contained in this product is stored in the SKIP database of the European Chemicals Agency (ECHA). This database serves transparency and ensures that relevant information on substances in products is publicly available. The SKIP number for the device is stored in the technical data of this manual, if necessary.

Further details on the substances contained as well as the requirements of the REACH Regulation can be provided on request.

## 2 System Description

The Econo 328 is a rugged industrial device that can be used as a gateway, automation controller, or edge computer. With a powerful Raspberry Pi Compute Module 4 and various interfaces, it enables data exchange and monitoring of processes. The FIO Controller 328 offers a modular control solution for industrial automation with CODESYS Runtime and various industrial interfaces for flexible expansion and data communication with other systems.

### 2.1 Econo 328

The Econo is a rugged device suitable for industrial use. It uses a Raspberry Pi Compute Module 4 with a powerful quad-core processor. It can be used as an industrial gateway, automation controller, or edge computer. The HDMI interface allows monitors to be connected to monitor processes. USB 3.0 ports allow you to connect storage devices and external devices. Data can be exchanged with other systems via Ethernet interfaces. The integrated mini UPS backs up data in the event of power outages.

### 2.2 Modular CODESYS controller, FIO controller 328

The FIO Controller 228/328 has hardware and software adapted to the requirements of industrial automation technology and has a powerful CODESYS runtime with integrated industrial interfaces.

The FIO Controller can be flexibly expanded and supplied with EtherCAT I/O modules from the Kuhnke FIO series via the E-Bus connection on the side. Additional decentralized EtherCAT subscribers are connected directly to the FIO Controller 228 via the EtherCAT OUT connector.

Data is exchanged with other systems via the integrated Industrial Ethernet interfaces such as EtherCAT, Modbus and optionally via Ethernet/IP or PROFINET. In addition, the IOT protocol OPC UA is available for data exchange. USB 3.0 interfaces allow the use of removable storage devices or external peripherals.



### Features

- Powerful modular control
- Expandable with all modules of the Kuhnke FIO-I/O modules
- Variable thanks to different software packages
- CODESYS SoftMotion and CNC+Robotics capable
- Networkable via LAN, OPC UA, EtherCAT®, and Modbus interfaces
- Maintenance-free due to fanless processor technology and RTC without battery

## 2.2.1 CODESYS

CODESYS is a software platform for many tasks in industrial automation technology. The basis is the IEC 61131-3 programming system. The tool offers the user integrated solutions for his work – with the aim of supporting him in the realisation of his task in a practical way.

### Development environment:

CODESYS offers an integrated development environment that CODESYS Development System. This IDE contains tools for programming, testing, simulation, and commissioning control applications.

### Programming languages:

CODESYS supports various programming languages, including the IEC 61131-3 programming languages, such as Structured Text (ST), Function Block Language (FBD), Instruction List (AWL), Ladder of Contacts (KOP), and Sequence Language (SFC). This allows developers to choose the programming language that best suits their needs.

### Target platforms:

CODESYS can be used to create applications for a variety of target platforms, including various PLCs and embedded control systems from different manufacturers. It is a vendor-agnostic platform that allows developers to flexibly choose between different hardware options.

### Integration:

CODESYS often offers the ability to integrate seamlessly with other automation systems and software solutions. This enables the development of complex control applications that can communicate with other parts of the automation system.

### Simulation:

The platform enables the simulation of control applications before they are implemented on the actual hardware. This helps in error detection and troubleshooting before deploying the application in the real environment.

## 2.2.2 CODESYS Building Blocks

### CODESYS Runtime

The soft PLC runtime system CODESYS Control is installed on the FIO Controller 228 / 328 and matched to the existing hardware. It turns the Econo into an IEC 61131-3 compliant industrial control system. In addition, this runtime system includes important additional functionality so that the controller can communicate with other components in the automation environment.

### CODESYS Visualization

Directly in the CODESYS programming system, the user can use the integrated editor to create complex visualization masks and animate them on the basis of the application variables. Integrated visualization elements are available for this purpose. The generated masks can be used, for example, for application tests and during commissioning in the online operation of the programming system. With the optional visualization clients **CODESYS HMI** and **CODESYS WebVisu**, the created masks can also be used to operate the machine or system.

### Software Options

The devices are equipped with various software options, which can also be installed in combination on the devices. Please ask support for your desired combination.

#### Software Options

Option	Marking	Function
--------	---------	----------

CODESYS WebVisu	<b>WV</b>	A control system with the CODESYS WebVisu allows you to display your masks created in CODESYS in any web browser, anywhere in the world.
CODESYS SoftMotion	<b>SM</b>	Single or multi-axis movements up to curve writing can be configured in the familiar IEC 61131-3 development interface - together with the logic application. A Motion FIO Controller with CODESYS SoftMotion implements the motion functionality in the form of a modular system in the PLC programming system. Motion FIO controllers with CODESYS SoftMotion allow users to create extensive configuration options for their motion tasks. Among other things, certified motion modules according to PLCopen and the full range of services of the IEC 61131-3 programming interface are available for this purpose.
CODESYS SoftMotion CNC+Robotics	<b>SM CNC*</b>	3D CNC motion control for Motion FIO controllers with full 3D CNC or robotics functionality including interpolator and kinematic transformations. CODESYS SoftMotion CNC+Robotics enables the user to conveniently configure complex robot axis groups with an integrated editor. In it, he can select the desired kinematics, parameterize them and connect them to the physical robot axes. The robot function is processed using standardized function modules in accordance with PLCopen MotionControl Part 4.

\* Please note that FIO controllers with the SM CNS software variant are subject to approval for export from the EU (e.g. as spare parts) in accordance with point 2D002 of the dual-use list of goods Appendix 1 Cat. 2. Find out about the licensing procedure at the responsible office (Germany: Federal Office of Economics and Export Control). If the device is installed in a machine with the SM CNC software version, the machine classification automatically applies.

Further information can be found on the product pages of CODESYS GmbH

## Linux PREEMPT RT

Linux is one of the most powerful embedded operating systems of our time due to the high number of supported CPU architectures, the almost infinite number of drivers, and the good portability and scalability. Even systems with hard real-time requirements can be easily implemented with Linux.

Pros:

- Real-time capability
- Low storage space requirement
- Wide range of drivers
- Multi Core compatible
- Long-term availability

Powered by Raspberry Pi



The Raspberry Pi 4 offers numerous advantages in industry. Thanks to its powerful quad-core processor and an industrial-grade chassis design, it handles demanding tasks effortlessly. Thanks to its various interfaces such as USB, LAN and HDMI, the Raspberry Pi 4 is extremely versatile and can be seamlessly integrated into industrial environments. The simple development and programming also supports developers in adapting solutions to specific requirements. Despite its small size, the Raspberry Pi 4 is extremely powerful and can be easily integrated into existing systems. The active support of the developer community and the leadership of the Raspberry Pi Foundation ensures continuous development and innovation, making it an excellent choice for industrial applications.

## 3 Product Description

### 3.1 General description

The Embedded Compact PC offers a powerful processor board with industrial interfaces and a real-time operating system. It can cover applications in the field of edge computing and PLC.

#### Econo 328

The Econo can be used in a variety of ways as an industrial gateway, automation control or edge computer. The HDMI interface can be used to connect monitors to monitor or operate the process.

#### FIO Controller

The FIO controller is equipped with a CODESYS Soft PLC as a controller. The controller can be flexibly expanded with EtherCAT I/O modules from the Kuhnke FIO series via the E-Bus connection on the side. Additional decentralized EtherCAT subscribers are connected directly to the Controller 328 via the EtherCAT OUT connector.

### 3.2 Front view Econo / FIO Controller 228



### 3.3 Front view Econo / FIO Controller328



### 3.4 Component Categorization

The present device is classified as a Category 3 component according to IEC 62443-4-2. This classification identifies a component with advanced networking and computing capabilities that has multiple communication interfaces and performs complex control functions in industrial automation systems.

### 3.5 Application area

The device is an embedded compact PC / PLC based on the Raspberry Pi Compute Module 4 for use in the control cabinet or terminal box.

This series of devices offers a flexible and powerful solution for a wide range of machine and control cabinet applications, including:

- Control: Use of standardized software solutions in all areas of mechanical engineering.
- Operation and visualization: Ideal for vending machines and information terminals.
- Combined visualization and control: Real-time control and visualization on a single system in general engineering.
- Modular CODESYS controller: Available with a variety of interfaces for flexible adaptation.
- IoT gateway and edge controller: For modern, connected applications.
- Process automation: As a reliable control system for demanding automation tasks.
- System integration: Efficient integration of a wide variety of systems and components.
- Industrial controls: Also suitable for safety-critical functions.

### 3.5.1 Intended use

This device is intended exclusively for use in industrial automation systems under controlled environmental conditions. Use is limited to the areas of application, environmental parameters and operating limits specified in the technical documentation. Any other use is considered non-intended and may result in safety risks, malfunctions or damage. The operator is fully responsible for the proper integration and use of the equipment in its system.

### 3.5.2 Terms of Use

The controller may only be used in applications where:

- There are no immediate safety risks for people
- System failures do not cause widespread economic damage
- System integrity is ensured by limited complexity
- The necessary cyber security measures cannot be adhered to

### 3.5.3 Foreseeable misuse

#### Location Requirements

The devices are open equipment that may only be installed and operated in lockable housings, cabinets or electrical operating rooms. Access may only be possible for trained or approved personnel. The applicable standards and guidelines for the construction of control cabinets and the arrangement of data and supply lines must be complied with. Make sure that there are no impairments in terms of temperature, impurities, shock, vibration and electromagnetic influence.

The waste heat of the device develops in the side panel, the aluminum heat sink. Sufficient ventilation of the installation area must be ensured.

	<b>NOTE</b>
	<p><b><i>Damage to the device</i></b></p> <p><i>The device can be damaged by the wrong choice of installation location.</i></p> <p>⇒ Please note the permissible ambient conditions and the installation position of the device in the Technical Data chapter.</p>

#### Risks from improper cyber security implementation

A foreseeable misuse occurs in particular if the device is used outside the intended industrial context of use or if no appropriate cyber security measures are implemented. These include, among other things, operation without sufficient network segmentation, the absence of access controls or integration into systems without a security concept. The manufacturer expressly points out that the responsibility for securing the component lies with the operator or system integrator. Inadequate implementation of the necessary protective measures can lead to security gaps and malfunctions.

## Design constraints for high-risk activities

The Product is not designed or intended for use in any customer system or in combination with any third-party materials where the failure or failure of the Product is proven to result in the death or serious bodily injury of any person or to any physical or environmental damage ("High Risk Use").

Its use in high-risk applications is strictly prohibited.

	<b>DANGER</b>
	<p><b><i>Danger of malfunction</i></b></p> <p><b><i>Death, serious personal injury or serious damage to property or the environment</i></b></p> <p>⇒ Its use in high-risk applications is strictly prohibited.</p>

## Completely excluded areas of application

The device must not be used in critical infrastructures under any circumstances, as these places particularly high demands on security and reliability. The excluded areas include, in particular, energy supply systems, water and sewerage systems, telecommunications networks and traffic control systems.

It is also excluded from use in safety-critical systems. These include medical devices and life support systems, safety-relevant automotive applications, aerospace systems, nuclear facilities, and rescue and emergency systems.

In addition, the use of the device in high-availability and security applications is prohibited. This applies in particular to systems that directly affect human lives, applications without sufficient resiliency, and systems where failure could have potentially catastrophic consequences.

These restrictions serve to comply with safety standards and protect against serious risks.

### 3.5.4 Disclaimer

If the defined intended use of the device is not adhered to, all warranty and conformity claims expire. This is especially true in the event of improper integration into industrial automation systems or failure to implement appropriate cyber security measures. In such cases, there is an increased risk of personal injury and property damage. Kendrion Kuhnke Automation assumes no liability for any resulting damage.

## 3.6 Technical data

### 3.6.1 General device data FIO Controller 328 / Econo 328

General device data			
Product name	FIO Controller 328 LAN	FIO Controller 328 CAN	Econo 328
Integrated I/Os			
Processor	Quad-core ARM Cortex A72 (4 x 1.5 GHz)		
RAM / ROM	2GB DDR4L / 256 Bytes EEPROM		
Remanent memory	128 kB in eMMC memory		
Drives	eMMC Memory 8 GByte		
Mass storage	µSD(HC) card slot up to 64 GByte		
Clock	Real-time clock with battery backup (16 weeks storage time) Accuracy 1ppm @ 25°C (<100 ms/day)		
Graphic Interface	HDMI interface, resolution up to 3840 × 2160p @ 60 Hz (4K)		
Software	Operating System: Linux PREEMPT_RT Application: Edge Computing, CODESYS PLC, WebVisu, Motion		
Support period	At least 5 years after sale (see serial number)		
Interfaces			
Networks	2 x Ethernet (SW) 1Gbit – RJ45		
	2 x LAN 10/100MBit/s RJ-45 (SW)		2 x LAN 10/100MBit/s RJ-45 (SW)
			1 x Ethernet 1Gbit – RJ45
Fieldbus interface	1 x EtherCAT- OUT RJ45 (1x E- Bus FIO-Systemstecker)		
		1 x CANopen / 1 x RS 485	-
Interfaces	2x USB 3.0, 1x USB 2.0		
Fieldbus interfaces*	EtherCAT Main Device, EtherNet/IP Scanner / Adapter, PROFINET Modbus TCP client/server, Modbus RTU client/server (FTDI) CANopen Manager via FIO module / extension		
Data exchange	OPC UA		-
Screen connection	HDMI-Interface (mini HDMI)  Maximum resolution: 3840 × 2160p @ 60 Hz (4K)		
E-Bus Power Supply	1.5 A @ 40°C 1.5 A @ 55°C with fan		-
Component category according to IEC 62443-4-2	Embedded Component Hardware or software component that is integrated into industrial devices or systems		
Conditions of use			
Installation location	Operation in a closed control cabinet		
Installation position	Vertical; Please clarify other installation positions with support		
Storage Temperature	-25°C....+70°C		
Operating Temperature	0°C... +40°C, in vertical installation position 0°C... +55°C, with fan and any installation position		

<b>Relative humidity</b>	Installation space:5...95% (at 25°C)	
<b>Mechanical properties</b>		
<b>Case</b>	IP 20, stainless steel, aluminum heat sink	
<b>Assembly</b>	On DIN rail (35 mm x 15 / 7.5 mm) by snapping	
<b>Dimensions (WxHxD)</b>	51 x 125 x 90 mm (without plug and mounting plate) With fan approx. 51 x 145 x 100 mm	
<b>Weight</b>	600 g	
<b>Power supply</b>		
	24 V DC (+20 / -15 %) <b>power supply</b> designed for control tasks, reverse polarity protection	12 VDC (9 – 28.8 VDC), power supply designed for control tasks, Reverse polarity protection
<b>Mini UPS</b>	1000 ms, Charging time: 100 ms	1000 ms
<b>Current consumption</b>		
<b>Cyber Resilience Classification (CRA)</b>	In preparation: Category Class 1; Regulation (EU) 2024/2847	
<b>Certification</b>	CE	
<b>SKIP Number</b>	Do not contain any substances of very high concern	

\*Technical data only exemplary for one version of the FIO Controller 328

### 3.6.2 Device Data PROFINET IO Device Extension

#### Additional device data

<b>Product name</b>	The abbreviation "PN" is used in the device designation
<b>Article number</b>	➔ 7.5 Ordering details
<b>Interfaces</b>	2x Ethernet (switch) PROFINET®
<b>Fieldbus</b>	PROFINET IO Device
<b>PROFINET Chip</b>	Hilscher netX 90 CommunicationFIO Controller
<b>Process data</b>	256 bytes out

### 3.6.3 Device Data EtherCAT Device Extension

#### Additional device data

<b>Product name</b>	The abbreviation "EC" is used in the device designation
<b>Article number</b>	➔ 7.5 Ordering details
<b>Interfaces</b>	2x EtherCAT (In / Out)
<b>Fieldbus</b>	EtherCAT Device
<b>Process data</b>	256 bytes out

### 3.6.4 Device Data Ethernet Expansion

#### Additional device data

<b>Product name</b>	The abbreviation "LAN" is used in the device name
<b>Article number</b>	➔ 7.5 Ordering details
<b>Interfaces</b>	2x Ethernet (Switch) 10Mbit, 100Mbit

### 3.6.5 Device Data LAN/CAN/RS-485 Expansion

#### Additional device data

<b>Product name</b>	The abbreviation "CAN" is used in the device designation
<b>Article number</b>	➔ 7.5 Ordering details
<b>Interfaces</b>	2x Ethernet (Switch) 10Mbit, 100Mbit

## 4 Structure and function

### 4.1 Short description

The Controller 328 is a rugged device for industrial applications. Equipped with a powerful Raspberry Pi Compute Module 4, it allows you to connect monitors via HDMI, exchange data via Ethernet interfaces, and connect external devices via USB 3.0.

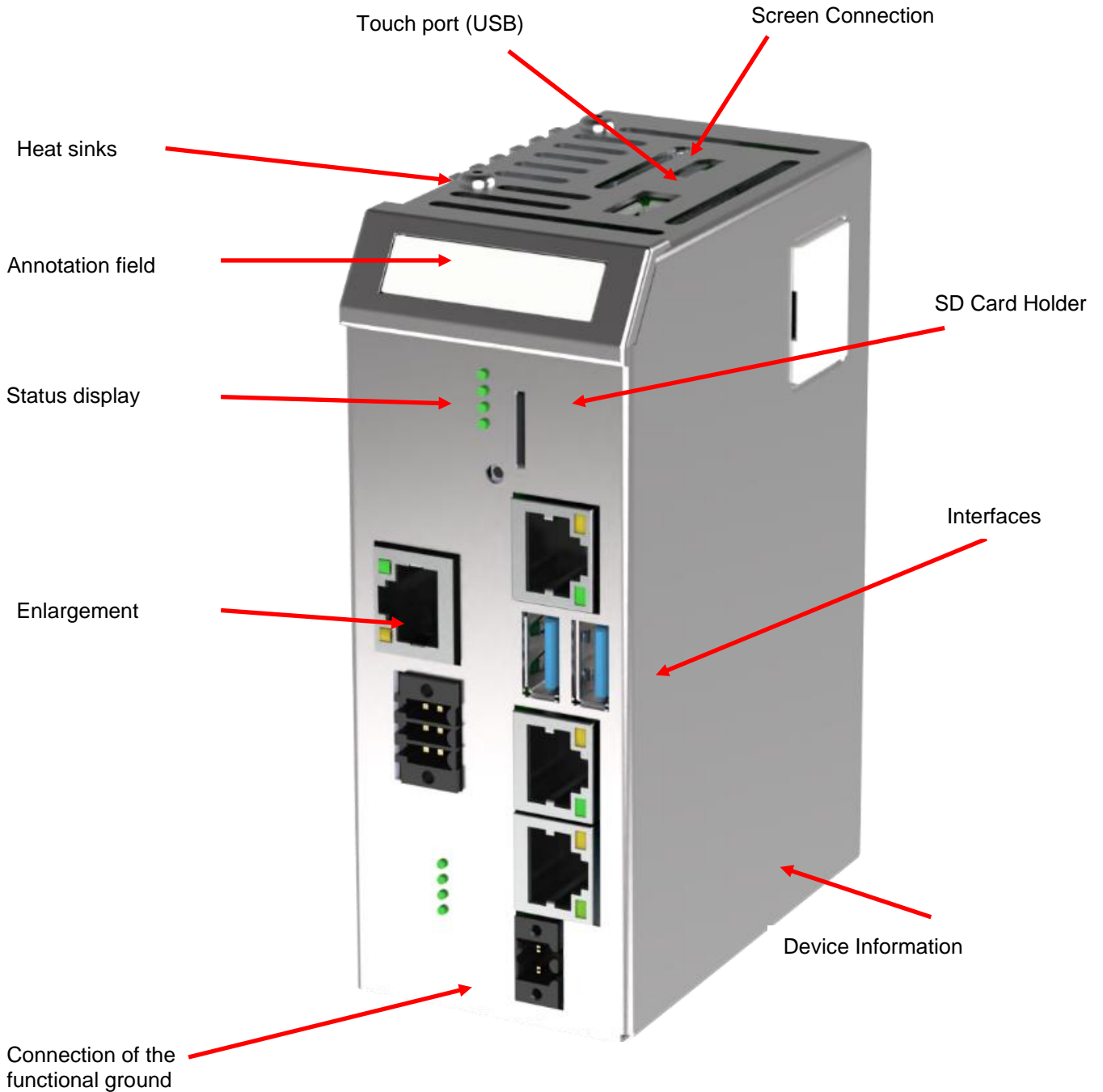

## 4.2 Product Identification

### 4.2.1 Device Information

#### Hardware design and nameplate

The device marking is permanently and tamper-proof on the side wall of the device by means of laser engraving. The following information can be found.

- Model name / order designation, order number
- Voltage and current specifications
- Degree of protection and CE marking
- Warnings

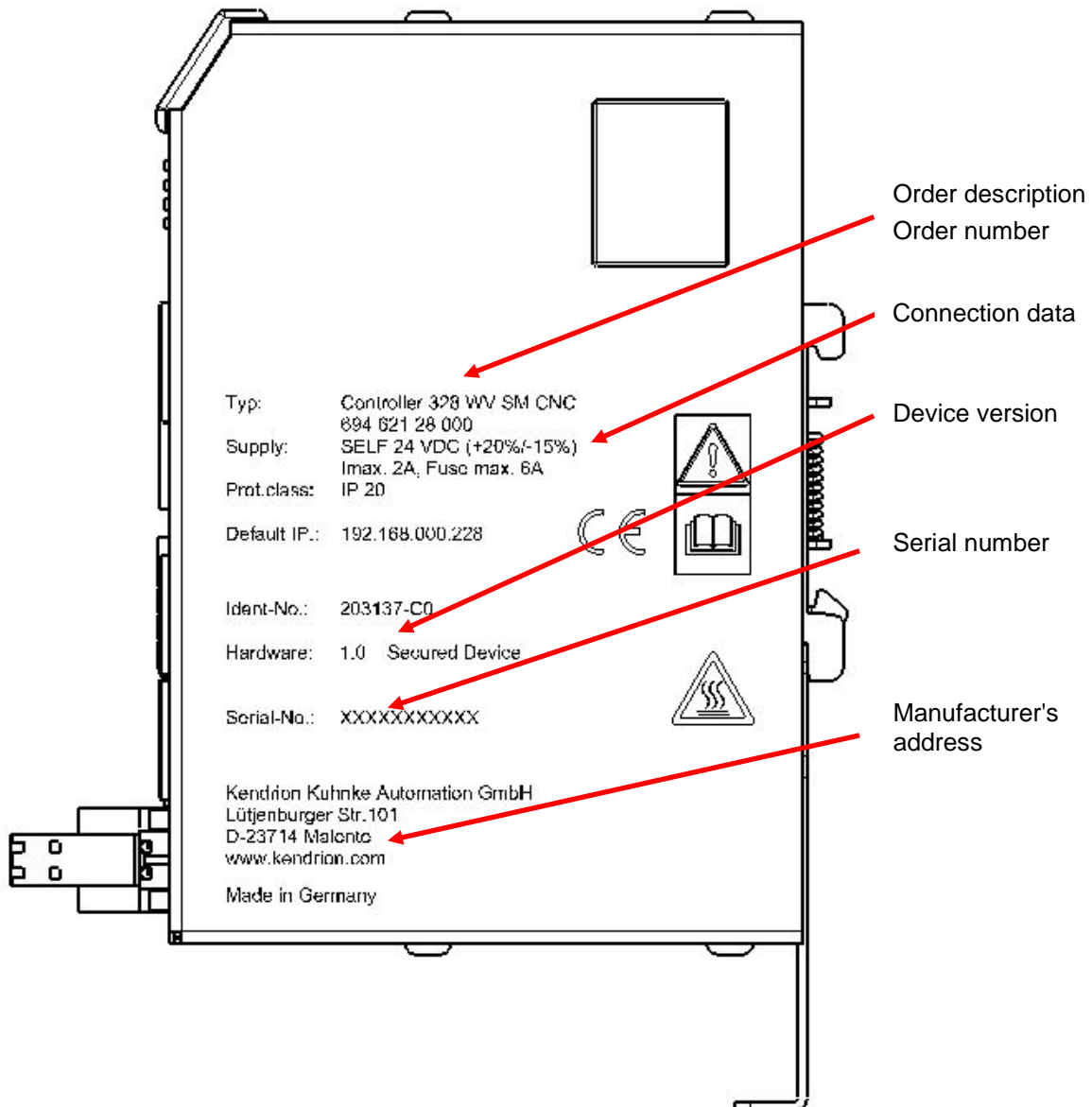

## 4.2.2 Serial number

The serial number is made up of the date of manufacture and a consecutive number. Based on this combination, Kendrion Kuhnke can clearly identify the device design as well as the software and hardware status. It serves to ensure complete traceability of the device. The serial number is located on the right side panel of the device.

Structure of the serial number:

JJ MM DD NNNNN

Example:

The device shown in the picture was manufactured in 05 June 2025 with the serial number 00039.

25 06 05 00039

Five-digit device construction number of the day

Date of manufacture in format: Year Month Day

## Version labelling on delivery

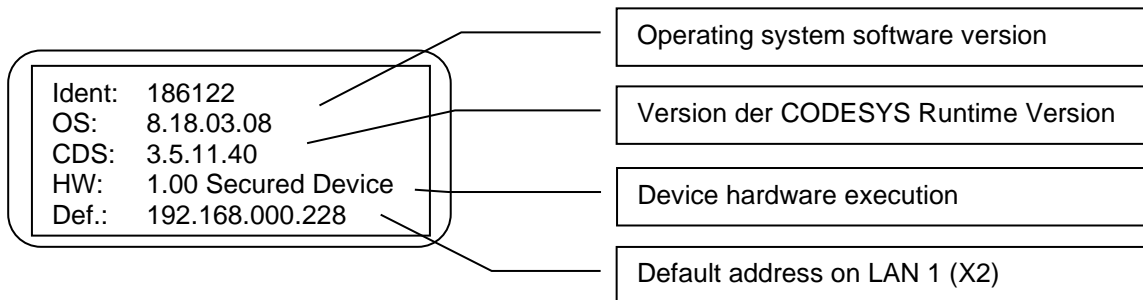

Note: The currently active version of the device can be determined via the web configurator.

## Software License Marking

Depending on the version, different license stickers for the operating system and the application software are fixed to the side of the device.

Accessoires

## 4.3 Scope of Delivery

The scope of delivery of the Econo consists of:  
Packaging, basic unit, insert, connector plug



## 4.1 Accessories

### Documentation

#### Applicable documents

Documentation	Title	Source
Package Insert	Supplement Device-specific	Device packaging Product finder Kendrion
E 868 DE/EN	User Manual Econo / FIO Controller 228 / 328 Embedded PC / Compact PLC	Product finder Kendrion
E 869 DE/EN	Software User Guide FIO Controller Control System	Product finder Kendrion

### Device Description

For all variants of the Scout with the iMX6 processor system, the device description "ContollerES6" is used. This can be downloaded from the device, as well as the device description for the optionally integrated 4DI/4DO in the web configurator in the "Download" menu.

#### Device Description

Device version	Device Name /Device Id	Source
FIO Controller 228 / 328	<i>FIO Controller x28</i>	Product finder Kendrion

## 4.2 Transport and storage

Despite the robust design, the built-in components are sensitive to strong shocks and shocks. Use the original packaging for transport and storage of the device. Make sure that the equipment is only transported and stored under the specified environmental conditions. For information about the permissible environmental conditions for transport, see 3.6.1 General device data FIO Controller 328 / Econo 328 in this guide

	<b>NOTE</b>
	<b>Humidity</b> <i>Damage to the device</i> ⇒ When transporting in cold weather or when the device is exposed to extreme temperature fluctuations, care must be taken to ensure that no moisture (condensation) precipitates on and in the device. The device must be slowly adjusted to the room temperature before commissioning.

### 4.2.1 Transport inspection

Upon receipt of the device, it must be ensured that the delivery is undamaged and complete.

- Check the packaging for external damage.
- In the event of serious damage to the packaging or recognizable damage to the contents, inform the carrier and your supplier immediately.
- Check the contents for recognizable transport damage.
- Please check the contents for completeness based on your order and keep all supplied documentation carefully.
- For possible further transport, keep the fixing packaging.

### 4.2.2 Packaging

The fixing packaging of the device is made of corrugated cardboard with additional tension film and quick-release fastener, which is reusable.

The packaging can be disposed of unseparated in the waste paper.

Please observe the locally applicable disposal regulations.

### 4.3 Connector Overview

The connection level for the external connections is located on the front, top and bottom of the device. All connections are pluggable.

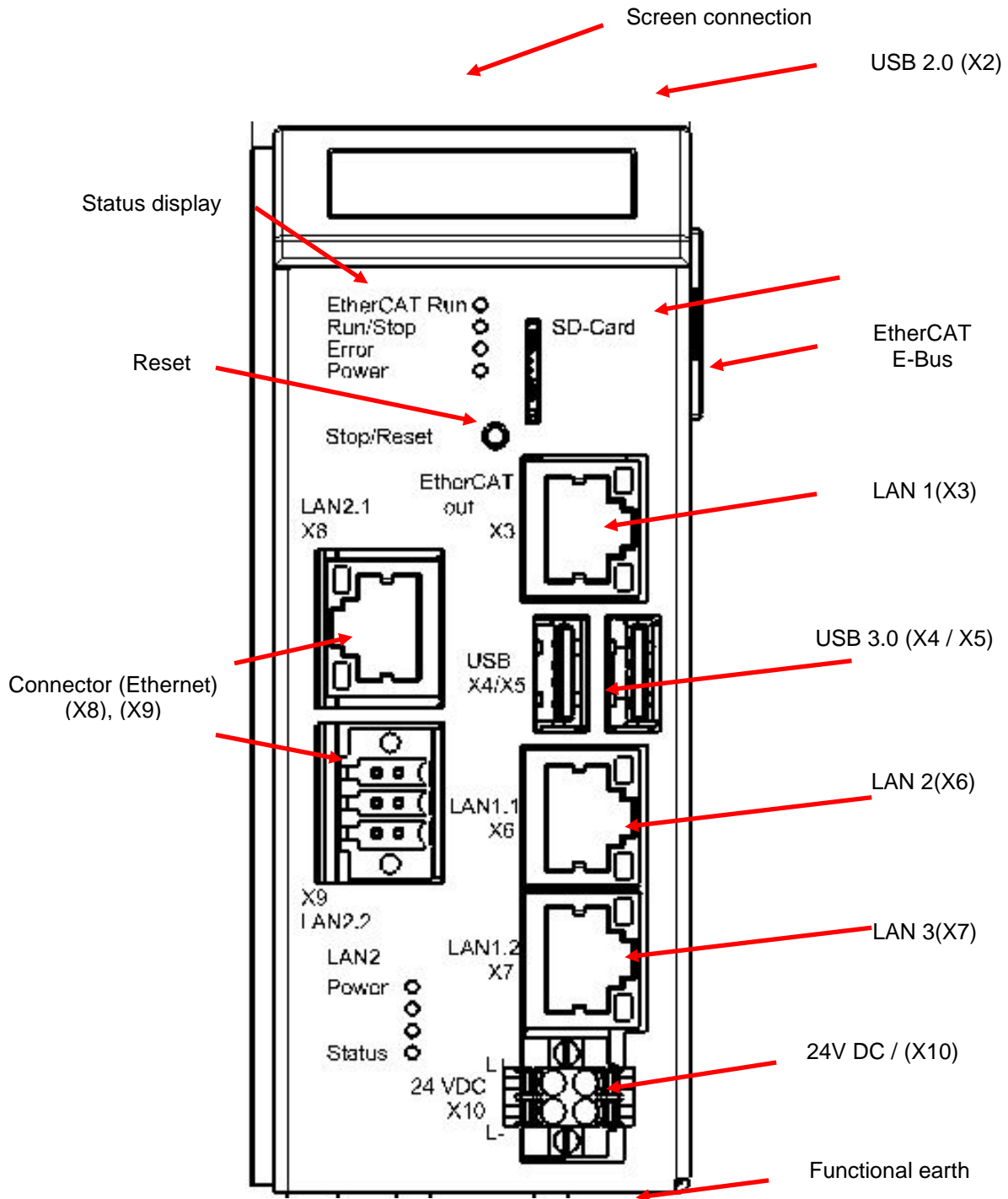

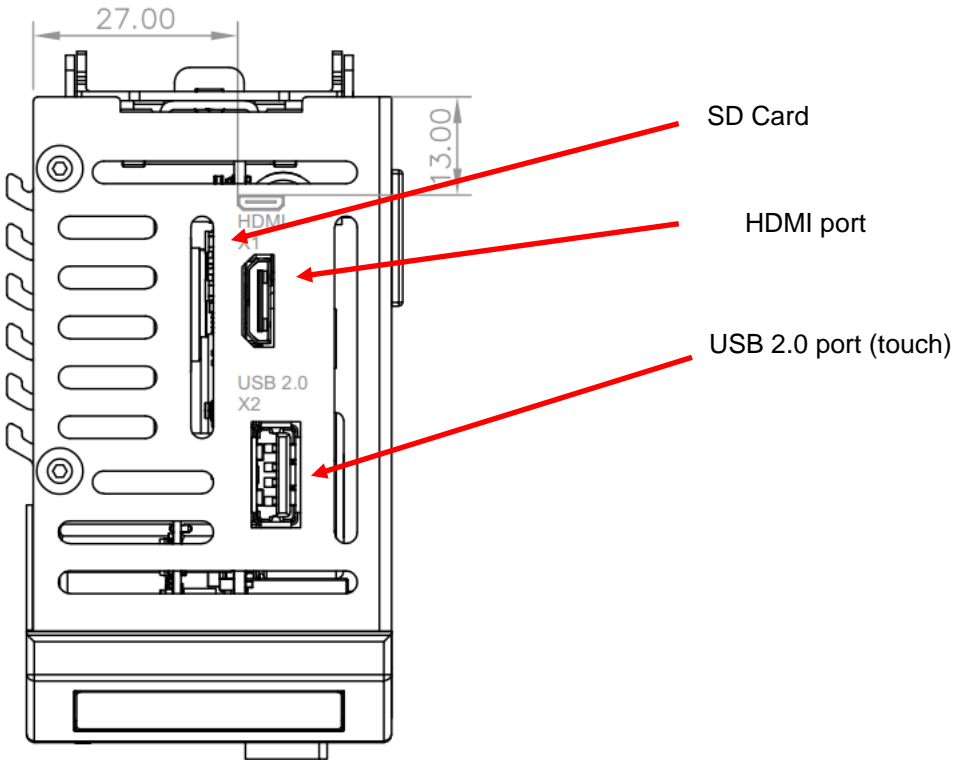

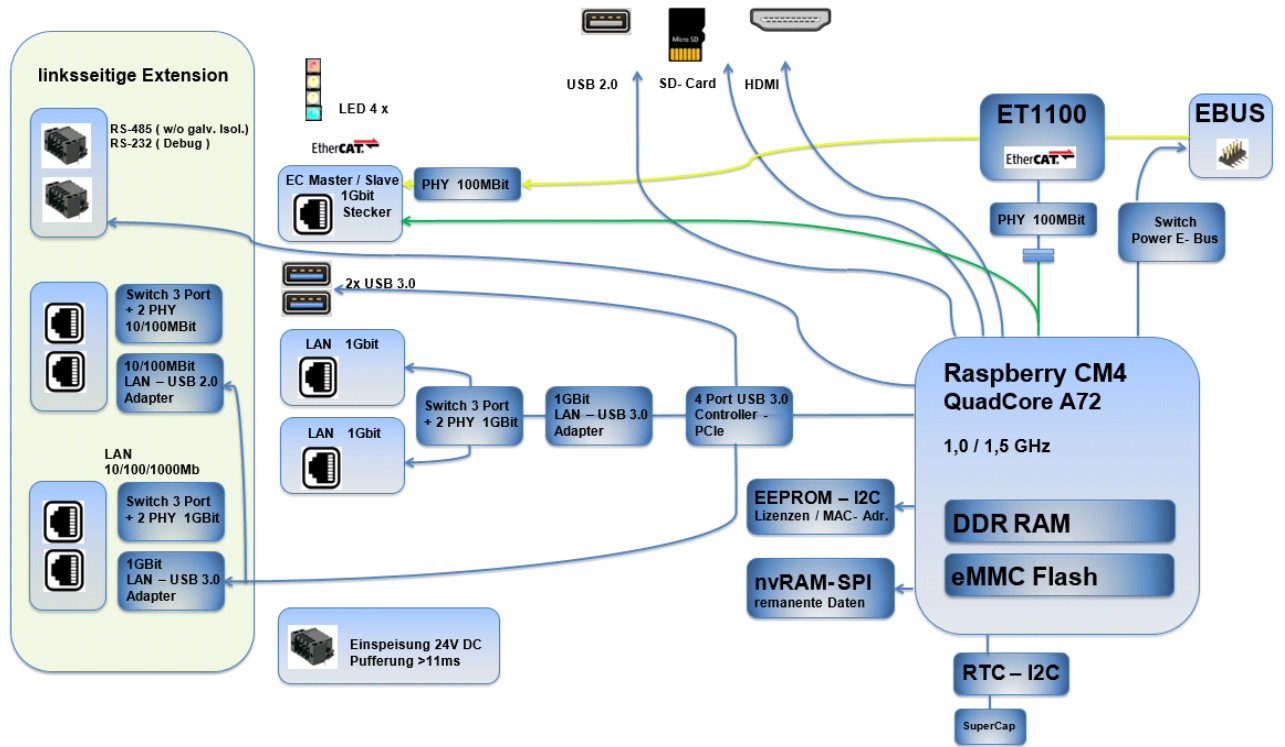

### 4.3.1 HDMI Graphics Interface, (X1)

HDMI stands for "High Definition Multimedia Interface" and is an interface for transmitting video material between PLC and monitors. The resolution of the monitor is automatically adopted and used for image transmission. The maximum system resolution is 3840 × 2160p @ 60 Hz. The interface is led out as a mini HDMI on the top of the device.

#### Connection data



X9 Mating plug	
Quantity	1
Type	Type C (HDMI min)

#### Technical data

HDMI	
Specification	HDMI 2.0
Video format	H.265 (up to 3840 × 2160p @ 60 Hz (4Kp60)) H.264 (up to 1920 x 1080@60 (1080p60))
Audio	optional
Configuration options	none
Cryptographic algorithms:	none

#### Touch screens

If a touch screen is used, the touch signals are transmitted via USB. The calibration of the touch screen is carried out via an associated calibration program. Please note that a calibration program for the operating system must be available.

Please use the USB 2.0 socket on the top of the device for the touch information.

### 4.3.2 "USB 2.0" (X2)

The USB port can be used to power various types of peripherals such as keyboards, mice, printers, and external hard drives. Additional drivers can be included on request.

A maximum current of 0.5 A is available at the USB ports. The total current of all USB ports of the device must not exceed 1.5 A.

#### Plug assignment:



X4 / X5 USB		
Plug	Pin	Function
USB	B1	VCC
	B2	D-
	B3	D+
	B4	GND

#### Connection data

X Mating plug	
Quantity	1
Type	Type A connector

#### Technical data

USB 2.0	
Speed	High-speed at 480 Mbps Full-speed with 12 Mbit/s, low-speed with 1.5 Mbit/s

Current carrying capacity	1,0 A Note: no support for charging batteries
Potential separation	No galvanic isolation
Configuration options	none
Cryptographic algorithms:	none

### 4.3.3 "EtherCAT Out" (X3)- Version FIO Controller

External EtherCAT subscribers can be connected directly to the EtherCAT OUT connector via RJ45 lines.

The status LEDs "LNK" and "RCV" provide information about a successful network connection.

Plug assignment:

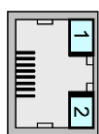

EtherCAT outX3

X3 LAN2		
Plug	Pin	Function
	2	TX
	3	RX+
	4	75 Ohm
	5	75 Ohm
	6	RX
	7	75 Ohm
	8	75 Ohm
LED "LNK"	green/orange	Connection data
LED "RCV"	orange	Activity

Technical data

EtherCAT Out		
Function	Connection of external EtherCAT participants	
Interface	EtherCAT Device FIO Controller	ASIC ET1100
Baudrate	100Mbit/s	
Cable Type	CAT5	
Cable length	max. 100m	
Configuration options	Network topology configuration	
Cryptographic algorithms:	None	

	<p><b>NOTE</b></p>
<p><i>For EtherCAT data cables, we recommend network cables of the category Cat5e SF/UTP. Unshielded cables must not be used.</i></p>	

### 4.3.4 Ethernet "LAN 0" (X3) in the Econo version

The on-board Ethernet adapter 10/100/1000 Mbit Base-T with RJ-45 connection enables network connection. In the runtime system, the LAN0 connection is routed with eth1.

The status LEDs "LNK" and "RCV" provide information about a successful network connection.

Plug assignment:

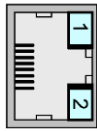

LAN0  
X3

X2 LAN0		
Plug	Pin	Function
 RJ45	1	TX+
	2	TX-
	3	RX+
	4	75 Ohm
	5	75 Ohm
	6	RX-
	7	75 Ohm
	8	75 Ohm
LED „LNK“	green/orange	Connection data
LED „RCV“	orange	Activity

### 4.3.5 "USB" USB 3.2 Gen1 (X4, X5)

Various peripherals such as keyboards, mice, printers and external hard drives can be connected to the device's USB ports. If necessary, additional device drivers can be integrated.

**Note:**

The maximum total current of all USB ports must not exceed 1.5 A.

The maximum data transfer rate is only achieved if all components involved support the USB 3.2 Gen 1 standard or higher. If devices with older USB standards are connected, the transfer speed is automatically adjusted to the respective specification of the connected device.

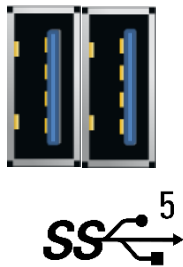

Plug assignment:

X4 / X5 USB		
Plug	Pin	Function
 USB	1	VCC
	2	D-
	3	D+
	4	GND
	5	SSRX-
	6	SSRX+
	7	GND_DRAIN
	8	SSTX-
	9	SSTX+
	Shell	Shield

Connection data

X9 Mating plug

Quantity	2
Type	Type A connector

## Technical data

USB 3.2 Gen1	
Speed	USB Super-Speed (5 Gbps), High-Speed (480 Mbps), Full-speed (12 Mbps), and low-speed (1.5 Mbps)
Current carrying capacity	1.0 A per port Note: no support for charging batteries
Potential separation	No galvanic isolation
Configuration options	none
Cryptographic algorithms:	none

## Use of USB sticks

When using USB flash drives, the following points should be considered:

- Unplugging a USB stick during operation is only allowed when all file operations have been completed, otherwise the USB stick may become unusable! If programs still have files open, the directory cannot be removed when the USB stick is removed. In this situation, file or directory operations lead to blocks, because it is supposed to read from a device that is no longer available in the system. Therefore, when pulling the USB stick, it should always be ensured that no program has open files in the USB stick.
- The file system used is FAT32, it has a partition and file size limit of 4 GB. FAT32 can only be used to format data carriers up to 2 TB. Other file systems can be implemented after consultation with product management.
- For safe operation, use USB sticks with SLC or pSLC technology in industrial design.
- A status LED in the USB stick simplifies handling of the storage medium.
- The mechanical design of the USB port is designed for a maximum of 1,000 mating cycles.

### Note: Use of USB Wi-Fi sticks

Due to Cyber **Resilience Act (CRA) requirements**, we do not support Wi-Fi USB flash drives. The CRA obliges manufacturers to implement comprehensive cybersecurity measures according to the principles of "**secure by design**" and "**secure by default**" for all products with digital elements – especially those with network functionality .

Since many commercially available WLAN sticks currently **do not fully meet these requirements** or do not offer sufficient transparency about their security architecture, their use on this device is **not planned**.

### 4.3.6 Ethernet "LAN 1.1" (X6), LAN 1.2 (X7) (switched)

Ethernet allows data packets to be transmitted between different devices on a local network. It supports a variety of network protocols and services, including TCP/IP for Internet communication, UDP for multimedia applications, and ICMP for network diagnostics.

Ethernet can operate at different speeds such as 10 Mbps (Ethernet), 100 Mbps (Fast Ethernet), 1 Gbps (Gigabit Ethernet). The on-board Ethernet adapters 1000 Mbit Base-T with RJ-45 connection enable network communication in a Gigabit Ethernet. The connections are switched.

The transmission standards are automatically detected and the interface is switched

The status LEDs "LNK" and "RCV" provide information about a successful network connection.

Plug assignment:

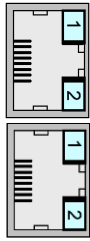

LAN1.1 / LAN1.2  
X6 / X7

X2, X3		LAN2 / LAN3	
Plug	Pin	Function	
 RJ45	S	Umbrella	Umbrella
	1	D1+	TX+
	2	D1-	TX-
	3	D2+	RX+
	4	D3+	
	5	D3-	
	6	D2-	RX
	7	D4+	
	8	D4-	
LED "LNK"	green/orange	Connection data	
LED "RCV"	orange	Activity	

	<b>NOTE</b>
	<p><b><i>Third-party access to the computer</i></b>  <i>Control failure and data loss</i></p> <p>⇒ When integrating into publicly accessible networks, the user must take appropriate measures to prevent unauthorized access.</p>

Technical data

Ethernet	
Function	Network communication
Interface	RJ 45
Baudrate	10 Mbps, 100 Mbps, 1 Gbps
Cable Type	CAT5 or better
Cable length	Depends on the transmission speed
Configuration options	IP addresses, subnet masks, and default gateways
Cryptographic algorithms:	None Expansion possible

## 4.3.7 Expansion Interfaces

### Ethernet LAN2.1 (X8)

The on-board Ethernet adapter 10/100/1000 Mbit Base-T with RJ-45 connection enables network connection. In the runtime system, the LAN1 connection is routed with eth1.

The status LEDs "LNK" and "RCV" provide information about a successful network connection.

Plug assignment:

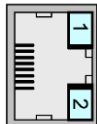

LAN2.1  
X8

X2		LAN1	
Plug	Pin	Function	
 RJ45	1	TX+	
	2	TX-	
	3	RX+	
	4	75 Ohm	
	5	75 Ohm	
	6	RX-	
	7	75 Ohm	
	8	75 Ohm	
LED „LNK“	green/orange	Connection data	
LED „RCV“	orange	Activity	

### 4.3.7.1 Serial Communication RS-485 / CAN (X9)

The CAN interface complies with the ISO 11898 standard and can be operated up to the maximum baud rate of 1 Mbit/s. The interfaces on the X7 connector are not potential-isolated. Both interfaces are internally equipped with termination resistors.

The **RS-485** interface is addressed in the system with COM1.

Plug Occupancy:

**RS-485**

**CANopen**

X7		CAN interface	
Pin	Function		
1	RS-485_Data (B) +		
2	RS485_Data (A) -		
3	RS-485_GND		
4	CAN_H		
5	CAN_L		
6	CAN_GND		

Connection data

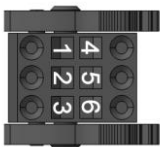

X9		Mating plug (example)	
Type	Double-row socket plug with PUSH IN spring connection		
Number of poles	6, Double row		
Ordering data	Weidmüller: 2446490000		
Conductor cross-section	min. 0.14 mm <sup>2</sup> max. 1.5 mm <sup>2</sup> (with AEH with collar max. 1 mm <sup>2</sup> )		
Screw flange	Tightening torque 0.25 Nm, screwdriver 0.4 x 2.5		

### 4.3.8 Power supply "24 VDC" (X10)

#### Internal power supply

The power supply is designed according to IEC 61131, which means that it is specifically designed for use in industrial control systems and meets higher standards in terms of reliability, environmental conditions and integration.

The device is intended for nominal voltage of 24 VDC (9 - 28.2 VDC). The power supply is potential-isolated and has integrated reverse polarity protection. The inrush current of the power supply is electronically limited to 2 A. The power supply supplies the CPU of the device and, in the FIO controller version, also the FIO modules connected to the e-bus.

The supply line and the power supply must be protected with external short-circuit and overload protection with a tripping current of max. 6 A. (NRTL)

#### Fan Supply FAN

A fan can be mounted as an accessory to cool the device. The fan is connected to the X10 connector. The power supply is regenerative and current-limited. For connection, the contact fasteners must be removed from the plug.

#### Plug assignment:

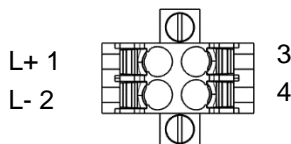

X9 Power supply 24 V DC	
Pin / Symbol	Function
1 / L+	external power supply 24 VDC (18V ... 32V)
2 / L-	external power supply GND
3 / FAN +	Fan Power Supply 5V
4 / FAN -	Fan Power Supply GND

#### Technical data

24V DC	
Voltage range	24 VDC (+25% /- 20%)
Current consumption	Max 2.5 A (@24 VDC)
Voltage interruption	FIO Controller: Up to 20 ms buffer time at 24 V DC and full load Econo Up to 500 ms buffer time at 24 V DC and full load
Standard	IEC 61131

#### Connection data



X9 Mating plug	
Type	Socket plug with spring connection (Push In)
Number of poles	4, Double row
Clamping range	0.14 mm <sup>2</sup> - 1.5 mm <sup>2</sup>
Ordering data	Weidmüller B2C/S2C Series 3.50 - 2-reihig 1277860000
Conductor cross-section	flexible min. 0.14 mm <sup>2</sup> flexible max. 1.5 mm <sup>2</sup> with ferrule according to DIN 46 228/1, max. 1.0 mm <sup>2</sup>

### 4.3.10 Functional Earth "X11"

The functional earthing of the device is carried out via the earthed DIN rail for devices with DIN rail mounting. To improve functional grounding and when mounting the device without a DIN rail adapter, the earthing conductor is connected via the 6.3 mm x 0.8 mm flat plug in the front of the device. The minimum cross-section must not be less than 2.5 mm<sup>2</sup>. The connection to the control cabinet terminal should be as short as possible.



#### **Information**

*A low-impedance ground connection improves the dissipation of interference transmitted to peripherals via external power cables, signal cables, or cables.*

### 4.3.11 $\mu$ SD(HC)-Card Slot



The device is designed with a  $\mu$ SD card slot. The slot is marked with an SD icon.

The file system used is FAT32, it has a partition and file size limit of 4 GB. FAT32 can only be used to format data carriers up to 2 TB. Other file systems can be implemented after consultation with product management. Gold-plated contacts guarantee low contact resistances and a service life of up to 10,000 mating cycles.

The SD card slot is equipped with a push-in/push-out insertion and ejection mechanism. To insert or remove the card, a flat object or tweezers may have to be used.

#### Technical data

$\mu$ SD(HC)-Card Slot	
Storage medium	MicroSD HC
Maximum file size	<4 GB
Maximum capacity	2 TB
Speed classes	2 / 4 / 6 / 10
Read	80 Mbps sequential read
Writing	10 MB/s sequential write

#### SD Card Recommendation

For optimal performance of your device, we recommend using an SD card with the following specifications:

Type: SDHC (Secure Digital High Capacity) oder SDXC (Secure Digital Extended Capacity)

Capacity: 4GB to 64GB (depending on your specific needs)

Speed class: Class 10 or higher

Industrial Grade

Brand: ATP, S700Sc Series

#### Comparison of industrial and commercial products

For the operation of the device in an industrial environment, industrial cards should be preferred to commercial SD cards.

Industrial SD cards offer:

- SLC or pSLC storage technology
- Secured write and erase cycles
- Longer availability with timely discontinuation

	<b>NOTE</b>
	<p><b><i>Electrostatic Discharge (ESD)</i></b>  <i>Destruction of the memory card due to improper handling</i></p> <p>⇒ SD cards are resistant to electrostatic discharges (ESD). Please always follow the instructions for handling memory cards.</p>

	<b>NOTE</b>
	<p><b><i>Error when inserting an SD card</i></b>  <i>Impairment of device function</i></p>

	<ul style="list-style-type: none"><li>⇒ If write commands are executed with a removed or defective SD card, the Linux system automatically creates a new drive in the flash memory of the device</li><li>⇒ Check the correct functioning of the SD card, e.g. with SSH.</li><li>⇒ Make sure that the storage media has been "unmounted" before ejecting.</li><li>⇒ For the operation of the device in an industrial environment, industrial cards should be preferred to commercial SD cards.</li></ul>
--	---

	<p><b>Information</b></p> <p><i>The SD card slot is not hot pluggable. This means that only cards that were inserted at boot time are recognized. It is not possible to replace the SD card during operation.</i></p>
---	---

### 4.3.12 Retain Variablen

For retain data, there is an NVRAM with a size of 8 kB in the device. The data stored in this non-volatile memory is retained even after the system is turned off or after a power failure. This is especially useful for storing configuration data and operational data that is collected over time.

	<b>Information</b>
	<i>In general, on systems with mass storage, it is important to question how useful it is to use larger amounts of retain data.</i>

### 4.3.13 Real Time Clock (RTC)

The device's precise real-time clock (RTC) stores the date and time regardless of the power supply. A capacitor buffers the data and the storage is maintained for up to 16 weeks at 25°C without further power supply.

The accuracy of the watch is 1 ppm, which is a deviation of < 100ms/day.

The clock can be set via web configuration or CODESYS V3 library.

## 4.4 Displays and Controls

### 4.4.1 Status Indicators (FIO Controller Version)

The status indicators provide information about the status of the device. The "User 1" and "User 2" displays can be assigned individual functions by the user.

Display:

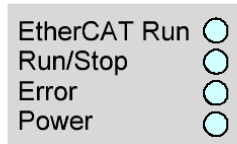

LED Significance		
Description	LED	Significance
EtherCAT Run	Off	Init, initialization state, no data exchange
	Out/Green, 1:1	Pre-op pre-operational state, no data exchange
	Out/Green, 5:1	Safe-Op, Safeoperational state, inputs are readable
	Green, Continuous Light	Operating room, operational state, full data exchange
Run/Stop	Off	No application loaded
	yellow	Device boots
	green	PLC is in the "run" state
	red (2x)	PLC is in the "stop" state
Error	Off	
	yellow	
	green	
	red	
Power	Off	No 24 V DC power supply
	blue	24 V DC power supply is available

EtherCAT out

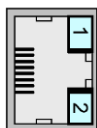

LED Importance for LAN interfaces		
Description	LED	Significance
1	Off	Not connected no Ethernet connection available
	Green Steady Light	Connected Ethernet connection is available
	Green Flashing Light	Traffic Traffic
2		

### 4.4.1 Status indicators (Econo version)

The status indicators provide information about the status of the device. The "User 1" and "User 2" displays can be assigned individual functions by the user.

Display:

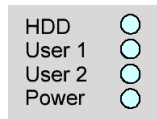

LED Significance		
Description	LED	Significance
HDD	Off	
	Green / yellow?	
User 1	Off	
	yellow	
	green	
	red	
User 2	Off	
	yellow	
	green	
	red	
Power	Off	Insufficient power supply
	blue	Power supply is available

Ethernet LAN 1

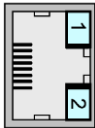

LED Importance for LAN interfaces		
Description	LED	Significance
1	Off	10 Mbit/s
	green	100 Mbit/s
	orange	1000 MBit/s
2	Off	
	orange	Connection exists
	Shines orange	Activity

Ethernet "LAN 2" (X6), LAN 3 (X7) (switched)

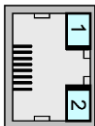

LED Importance for LAN interfaces		
Description	LED	Significance
1		
	Flashing yellow	100 Mbit/s
2		
	Flashing green	1000 MBit

### 4.5.1 Start / Stop -Taster "Start / Stop"

The start/stop button is located on the front of the device below the status indicators.

To avoid unintentional operation, the stop/reset button can only be operated with a sharp object (ballpoint pen, screwdriver).

Pressing for less than 2 seconds for the first time triggers the "stop" of the CODESYS PLC program. The Run/Stop status indicator changes from green to red. Pressing it again for less than 2 seconds triggers the "start" of the CODESYS PLC program again, the status indicator Start / Stop changes from red to green ... etc.

If the start/stop button is pressed for more than 3 seconds, a reset of the device is triggered. The Start/Stop status indicator changes from red to orange. The start/reset button can be released. The device boots.

#### Service Mode

To enter Service Mode, the device must be switched off. Then the button is held down and the device is switched on again. The button must be held down until the start/stop LED flashes yellow at intervals of 2 seconds

## 4.6 Accessories and Tools

### 4.6.1 Fans with EMC shield terminals

The fan ensures that the device is optimally cooled and thus a stable and powerful performance is guaranteed even in adverse environmental conditions.

#### Installation and connection

The carrier plate for the fan and the EMC terminals is screwed to the device from below with the screws supplied. Please be sure to install the finger guard grille for the fan. The connection cables of the fan are pulled to the front and connected to the terminals there. Make sure the plug is properly seated and plugged in tightly. When applying the supply voltage, observe whether the fan rotates and blows air properly into the device.

X9 Power supply 24 V DC		
Pin / Symbol	Function	Core color
3 / FAN +	Fan Power Supply 5V	red
4 / FAN -	Fan Power Supply GND	black

For an optimal result, there must be at least 50 mm of free space above the device.



### Shielding Terminal Blocks

The shield terminal blocks are mounted directly on the conductive carrier plate by simply swinging open. With the help of the knurled screw of the shield clamp, the cables are clamped in place. The slot at the top of

the thumbscrew allows for higher torque through the use of a standard screwdriver. The pressure piece of the shield clamp ensures high contact quality. The large contact pad ensures optimal shielding attenuation. Unwanted interference can be reliably dissipated to the PE potential.

Note: The shield terminals must not be used for strain relief.

## 5 Installation and operation

	<b>Information</b>
	<i>Before installing, commissioning and maintaining the Econo, please also read the safety instructions in the foreword of this documentation.</i>

### 5.1 Installation Environment

For the safe operation of the Category 3 component according to IEC 62443-4-2, the installation environment must be designed in such a way that basic cyber security measures are guaranteed. These include structured network segmentation with firewalls and, where appropriate, industrial DMZs to isolate critical systems, as well as restricting network access to authorized users and devices. Strong authentication procedures and role-based access controls (RBAC) must be implemented according to the principle of minimum privilege. The environment must allow for continuous monitoring of network communications, including anomaly detection and logging of security-related events. In addition, reliable software and firmware management must be ensured, which includes regular updates, patch management and the use of trusted configurations.

### 5.2 Mechanical installation

#### 5.2.1 Assembly

The FIO Controller is a modern electronic assembly that requires care in its handling, i.e. especially in assembly, operation and care.

It is intended for installation in the control cabinet on the DIN rails (according to DIN EN 60715 TH).

In order to ensure sufficient ventilation, the minimum distance of 30 mm upwards and 30 mm downwards from neighbouring devices and control cabinet surfaces must not be undercut. The device can be arranged with other devices.

Observe the permissible ambient conditions for storage and operation specified in the technical data.

	<b>Information</b>
	<i>The device is only approved for operation in closed control cabinets or rooms. When installing it in a control cabinet, observe the relevant DIN/VDE regulations or the respective country-specific regulations.</i>

	<b>Information</b>
	<i>Please note that the fasteners can safely support the connection cables in addition to the dead weight of the device.</i>

## Preparation of the device

Before mounting the device on the DIN rail, the optional fan should be pre-mounted on the bottom of the device. To do this, use the supplied mounting screws to securely attach the fan (40 x 40 mm) including EMC mounting plate, connection cables, finger protection grille and mounting material. The mounting plate is attached directly under the device. The power supply of the fan is via the power supply terminal X10 on the front of the device red to L+ and the black cable to L-.

## Installation of the optional shield connection terminals

The optional shield connection terminals – optionally in a 14 mm or 8 mm version – are mounted directly on the EMC mounting plate by simply swinging open. No additional fastening is necessary. Depending on the requirements, both the smaller and the larger clamp can be flexibly positioned. The following mounting variants are available and enable application-specific adaptation of the shield connections.

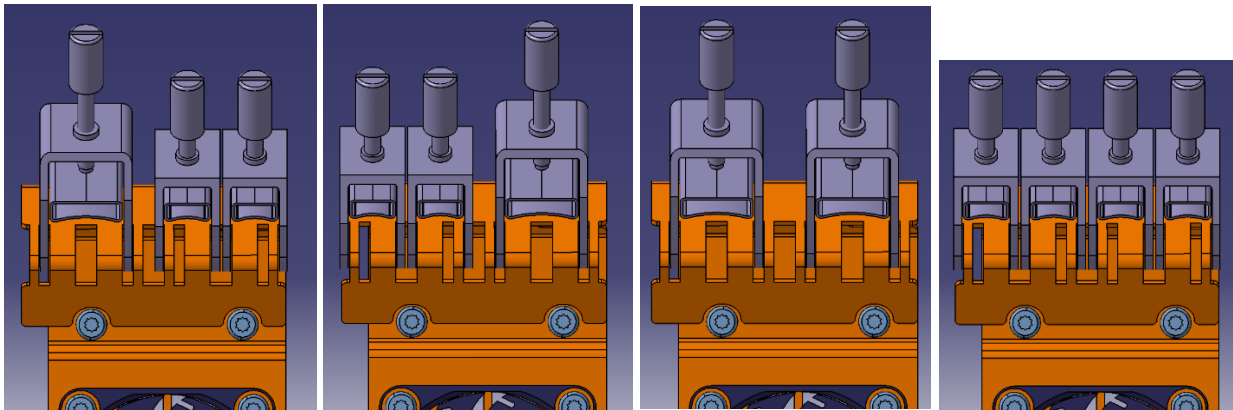

## Mounting on the DIN rail

The device is intended for mounting on DIN rails (according to DIN EN 60715 TH) with 35mm (TH 35). The DIN rail is mounted horizontally, the Ethernet connections of the device point forward.

Assembly steps:

- ⇒ Place the device with the DIN rail adapter on top of the DIN rail
- ⇒ Pull down the retaining spring of the clamp with a screwdriver and open the holder.
- ⇒ Place the device straight on the rail.
- ⇒ Relieving the retaining spring

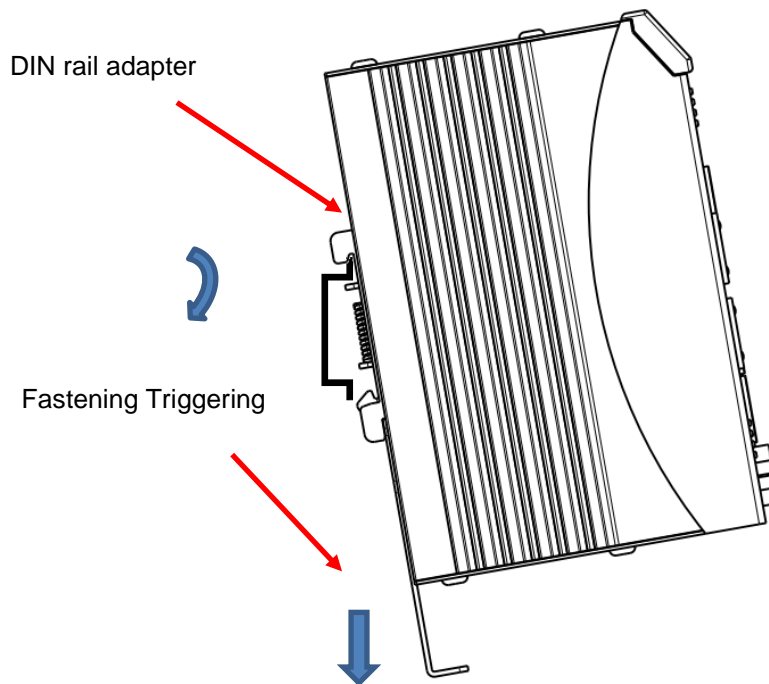

## Disassembly of the DIN rail

- ⇒ Pull down the retaining spring of the clamp with a screwdriver and open the holder.
- ⇒ Swivel the device from the bottom of the rail.
- ⇒ Remove the device from the DIN rail.

## Variant of installation

In confined spaces and in combination with FIO I/O modules, the DIN rail adapter can be rotated 180° and mounted on the device. To do this, loosen the four mounting screws, turn the adapter 180° and then attach it again to the back of the device with the four screws. The release mechanism can now be operated above the device..

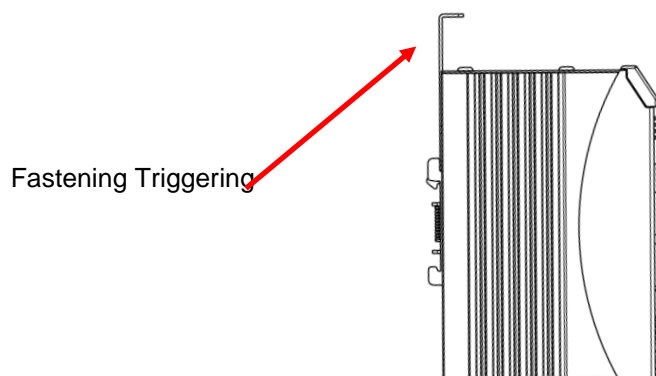

## 5.3 Electrical installation

The connectors are located on the front and top of the controller and are described in detail in the "Connector Overview" section. When connecting the cables to the controller, the following sequence must be observed:

- ⇒ Turn off the machine and disconnect the machine from the power supply
- ⇒ connect all the wires on the controller and on the devices to be connected,
- ⇒ make sure that all connections between plugs and sockets are perfectly tight!
- ⇒ Reconnect the machine to the power supply.

### 5.3.1 Functional earth

The functional earth is not a protective measure, but serves exclusively to improve interference resistance. It is used to dissipate electrical interference but does not provide contact protection for people. The functional earth is connected by fastening it to the earthed DIN rail. In order to ensure safe dissipation of electrical disturbances, the functional earth should be connected to the central earthing point in the control cabinet by the shortest possible route.

This procedure ensures that faults are effectively deflected.

	<b>Information</b>
	<i>Grounding lines should be short and have a large surface area. (copper mesh). Information can be found e.g. under <a href="http://de.wikipedia.org/wiki/Masse_(Electronics)">http://de.wikipedia.org/wiki/Masse_(Electronics)</a></i>

### 5.3.2 Connection to the FIO modules

The electrical connection between the FIO controller and the expansion modules of the FIO I/O series is made by pushing the individual devices together. The connection to the EtherCAT bus system and the power supply of the EtherCAT communication modules are established automatically. The FIO controller 228/328 is the first module and is located in the left position of a FIO block.

Please note that the number of FIO modules mounted on the device is limited by the maximum available E-Bus power supply of the FIO controller 228/328. Each additional module increases the power requirement on the e-bus and thus puts a strain on the internal power supply of the controller. Exceeding the permissible e-bus load can lead to unstable behavior or module shutdowns.

At the same time, the supply of several modules also increases the thermal load within the device, as the heat dissipated increases in proportion to the electricity consumption. This leads to additional heating of the CPU-environment and thus influences the entire germäTemperature. A sufficient amount of üand the Ümonitoring of the system temperature must therefore be ensured.

→ 3.6.1 General device data FIO Controller 328 / Econo 328

#### Connecting two modules

After attaching the FIO controller to the DIN rail, place the first FIO module on the right side with a distance of about 1 cm from the FIO controller on the DIN rail. Slide the FIO module seamlessly up to the controller.

#### Disconnecting the modules

Press the release lever of the FIO module that you want to disconnect from the FIO controller to the left. At the same time, push both modules about 1 cm apart.

### 5.3.3 System supply

The power supply of the device is provided by the terminals L+ and L- of the X10 plug. Conductors with a cross-section of 0.14 mm<sup>2</sup> to 1.0 mm<sup>2</sup> and ferrules can be used. Please note the current consumption of the device. The conductors with the ferrules can be pressed into the terminal without tools (push-in).

When wiring, make sure that the plug assignment of the power supply connection on the device is correct.

	<b>CAUTION</b>
	<p><b>Damage to the device due to too high or incorrect power supply</b>  <i>An incorrect voltage or polarity on the terminals can destroy the device.</i></p> <p>⇒ Please use the plug marking on the device</p> <p><b>5.3.4 Use the information from the connector overview 4.3.9</b></p> <p>⇒</p>

### Protection

The supply line must be protected with external short-circuit and overload protection with a tripping current of max. 6.25 A, min. 60V.

### Connection example power supply (version

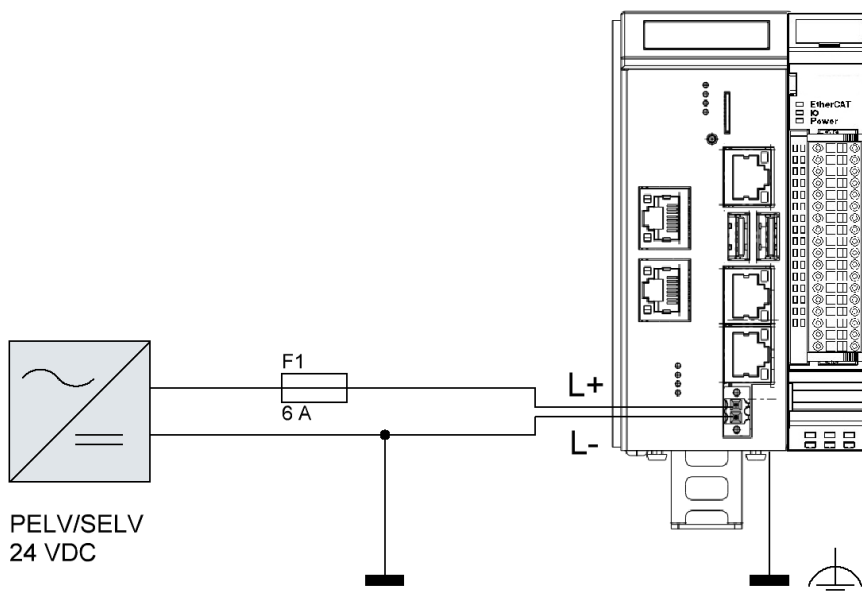

### E-bus supply

The FIO Controller 228/328 takes over the system supply of the attached FIO I/O modules. The FIO controller can provide up to 1.5 A of current for the FIO I/O modules.

### 5.3.5 EtherCAT

The modular control system can be flexibly expanded with EtherCAT I/O modules from the Kuhnke FIO series via the E-Bus connection on the side. Between the modules, the EtherCAT signals are transmitted with LVDS. At the same time as the EtherCAT signals, the FIO I/O modules are supplied with power via the system bus.

Other decentralized EtherCAT subscribers are connected directly to the FIO Controller 228/328 via the EtherCAT OUT connector.

Please note the following information for the safe operation of an EtherCAT fieldbus system.

- To connect EtherCAT devices, only use Ethernet cables that comply with at least Category 5 (CAT5) according to EN 50173 bzw. ISO/IEC 11801.
- Due to the automatic cable detection (auto-crossing), you can use both balanced (1:1) and cross-over cables between EtherCAT devices.
- The permissible cable length between two EtherCAT devices may not exceed 100 meters.

	<p><b>Information</b></p> <p><i>Torsions and continuous tensile load close to the connector of the Ethernet cable put a strain on the connections. If the Ethernet connector sits in the socket with a lot of play and is not sufficiently guided, tilting effects occur with the connectors. This often leads to contact interruptions and thus to fieldbus interruptions.</i></p> <p><i>Vibration tests show that the deeper the plug sits in the socket, the more robust the connection. In the industrial sector, the mechanical requirements in terms of vibration and shock resistance are known to be higher than in the IT sector.</i></p> <p><i>Depending on the manufacturer and system, the insertion depths of the plugs available on the market vary from about 8 mm to almost 12 mm. Standard plugs are around 9 mm insertion depth. According to the manufacturer, connectors designed for the industrial sector reach up to 11.8 mm.</i></p>
---	--

### 5.3.6 Modbus TCP

The "Transport Control Protocol" (TCP) is used in Ethernet TCP/IP networks to transmit the Modbus application protocol Modbus TCP. The protocol can be carried out on the device via the LAN 1 or LAN 2 interface. The selection is made in the CODESYS Development System in the Modbus configuration.

### 5.3.7 Connection of screens and touch function

The device has a mini-HDMI interface on the top for connecting screens with a resolution of up to 4K. To transmit touch information from a touch screen, the USB port on the top of the device can be used in parallel.

	<p><b>Information</b></p> <p><i>HDMI is not designed for industrial use. Long cables, low-quality cables, the routing of the cable or a very high screen resolution can lead to EMC interference in the machine.</i></p> <ul style="list-style-type: none"> <li>• <i>Use high-quality HDMI cables with a maximum length of 3 meters.</i></li> <li>• <i>To reduce EMC radiation, a ferrite core (e.g. from Würth) can also be attached to the HDMI cable.</i></li> </ul>
---	---

### HDMI Line Connection

The HDMI line may only be plugged in or removed when the power is de-energized. If the device is connected or disconnected while the device is turned on, the screen output may be permanently damaged.

	<b>CAUTION</b>
	<p><b><i>Improper handling of the HDMI connection when the device is turned on.</i></b>  <i>The screen output may be permanently damaged.</i></p> <p><b>5.3.8 Only plug or remove the HDMI line when the device is de-energized</b></p> <p>⇒</p>

## 5.4 Initial commissioning

### 5.4.1 General information on commissioning

	<b>NOTE</b>
	<p><b><i>Risk of burns</i></b>  <i>The surface of the device can reach a temperature of up to 70 °C. Any unprotected touch can lead to burns.</i></p> <p>⇒ Avoid touching the device directly during operation. Only handle the device with suitable protective gloves.</p>

The following tools should be available for initial commissioning:

- A USB keyboard
- A USB mouse
- Device with web browser

### 5.4.2 Prerequisites for commissioning

- The function earthing system is connected.
- The connecting cables are plugged in correctly.
- The device is connected to the power supply.

### 5.4.3 Turn on the device

Connect the device to the power supply.

After the start-up routine, the interface of the operating system is displayed. The screen resolution is selected in the image. If the device is equipped with a soft PLC, it is started automatically.

### 5.4.4 Turn off the device

There is no switch-off routine for the devices, the power supply may be taken directly from the device.

## 5.5 Configuration

The device is configured via a web interface. After logging in, you have the option of making various system settings or retrieving system information.

Details on the web interface can be found in the Software User Manual E 865. The Software User Guide is published in Kendrion's Product Finder.

### 5.5.1 Webinterface

#### IP address

The devices have a fixed IP address and subnet mask in the state of delivery.

IP- LAN Address 1 (X2):192.168.0.228

Subnet Mask: 255.255.255.0

In order to connect to the device for the first time, you must be in the same IP address range as the device with your PC.

If necessary, change the IP address of your PC accordingly.

	<b>NOTE</b>
	<p><b><i>Dual assignment of IP addresses</i></b></p> <p><i>Dual assignment of IP addresses can lead to severe disruption in a network.</i></p> <ul style="list-style-type: none"><li>⇒ Make sure that there are no duplicate IP addresses on your network.</li><li>⇒ For the first commissioning of the device, we recommend a direct network connection between the device and the programming PC with fixed IP addresses. You may need a cross-over network cable for this.</li></ul>

#### Clear assignment of the network address of the Ethernet interfaces.

If both network interfaces are given the same network address (net ID) and operate on the same subnet, it is not certain which of the two interfaces will be used for the data traffic. For secure operation, the network addresses (net ID) of the interfaces must be different. The network address (Net-ID) refers to computers and not to an Ethernet interface.

If the devices connected to the Ethernet interfaces have to work in a network, an external switch can be used for this purpose.

	<b>NOTE</b>
	<p><b><i>Same network addresses (Net-ID) at the interfaces of a device</i></b></p> <p><i>If the network interfaces of a device are operated with the same network addresses, interference can occur.</i></p> <ul style="list-style-type: none"><li>⇒ Make sure that the Ethernet interfaces of a device have different network addresses (Net-ID).</li></ul>

## 5.6 Diagnosis

### 5.6.1 Show

	<p><b>Information</b></p> <p><i>For information about the device's displays, see 4.4.1 Status Indicators (FIO Controller Version) and Fehler! Verweisquelle konnte nicht gefunden werden. Fehler! Verweisquelle konnte nicht gefunden werden. of this guide.</i></p>
---	--

### 5.6.2 Fault table

Fault table		
Error description	Possible cause	Recommended action
The date and time are not permanently stored	B	
No network connection		
CODESYS Stop		

## 5.7 Maintenance / Repair

### 5.7.1 General

Work on the Econo / FIO Controller 228 / 328 may only be carried out by qualified personnel.

	<b>CAUTION</b>
	<p><b><i>Incorrect or too high supply voltage</i></b>  <i>Risk of electric shock</i></p> <p>⇒ Do not plug in, hang up, loosen or touch connections during operation! Destruction or malfunction can be the result. Switch off all feeds before working on the device; also those from connected peripherals, such as externally powered encoders, programming devices, etc.</p>

### 5.7.2 Maintenance work

The device is maintenance-free for the stated service life and does not require any measures if it is stored and operated in the permissible environmental conditions specified in the specifications.

### 5.7.3 Maintenance

## 5.8 Lifespan

### 5.8.1 Repairs / Customer Service

	<b>Information</b>
	<p><i>Repairs and overhauls may only be carried out by the manufacturer or its authorized customer service.</i></p>

### 5.8.2 Warranty

The legal warranty applies. It expires if unauthorized repair attempts or other interventions are made to the device/product.

### 5.8.3 Decommissioning

This instruction describes the steps to safely decommission the controller, in particular with regard to the removal of all stored information by using the "Factory Reset" function in the service mode of the web interface. Detailed information on the web interface can be found in the software user bay E 869 DE.

- Make sure you have administrator privileges for the device.
- Put the device in Service Mode and use the "Factory Reset" function
- Check if the device only shows the factory settings.

	<b>Information</b>
	<p><i>Irreversibility: The Factory Reset irreversibly removes all stored information, including user data, passwords, SL licenses, and configurations.</i></p>

### 5.8.4 Disposal

- Disconnect the device from the power supply.
- Remove all cables and accessories

- To dispose of it, the device must be disassembled and completely disassembled into its parts.

### Electronic waste

All metallic individual parts can be sent for metal recycling.

All electronic parts must be sorted and disposed of. Details of disposal are regulated by national regulations and laws. These must be complied with during disposal.

The packaging must be recycled for paper and cardboard.

## 6 Specific device functions

### 6.1 System Information

Hardware-specific functions of the device are to be used with the "KICS FIO Controller ES6 System Library" in CODESYS. The library must be integrated into the project via the library manager.

In the library administrator, short documentation is stored for all usable function blocks and functions. For more information, please contact Kendrion Kuhnke's support.

Details on the "KICS FIO Controller ES6 System Library" can be found in the Software User Manual E 865. The user manual is published in the Kendrion product finder.

### 6.2 Undervoltage detection

The undervoltage detection in the device has the task of detecting deviations in the power supply. If the voltage provided falls below the threshold value of 19.2 VDC and 9.0 VDC, one signal is triggered each.

In the case of an FIO controller, the CODESYS controller is shut down in a defined manner at the threshold of 19.2 VDC. The outputs are switched off, the remanent data is stored and the controller goes into the stop state (IEC 61131).

Up to an operating voltage of 9.0 VDC, the Mini UPS can supply the energy for the specified operating time of the CPU in the event of a total failure of the power supply.

### 6.3 Mini UPS

Short-term power outages or voltage dips can be problematic for electronic controls. The Mini UPS with capacitor storage integrated in the device bridges short-term interruptions and provides sufficient energy for a safe shutdown of the controller in the event of a power failure.

The Mini UPS has a short charging time of 100 ms and operates in the voltage range of 9 to 28.8 VDC.

The device's built-in undervoltage detection provides signals that can be processed by the CPU.

### 6.4 Memory usage



#### Service life of flash cells

The lifespan of non-volatile cells of flash memory is limited to a number of write and erase (P/E) cycles. Each time a flash memory is written to or erased, the number of possible write and erase cycles decreases until the flash memory can no longer be used. Intelligent flash controllers distribute programming cycles across all memory cells (wear-leveling) and thus extend the useful life of flash memory.

Data that needs to be written frequently, such as log data, should be stored on the SD card with SLC technology. SLC flash memory cards have a lifespan of about 100 times longer and are also replaceable.

#### Handling instructions:

- Keep write and erase cycles low
- Offload frequent data storage to SD cards
- Use SLC cards instead of MLC cards
- Use cards with the largest possible cells

## Lifetime of eMMC memory

The 328 controller's internal eMMC memory utilizes an intelligent memory controller that makes optimal use of free memory areas and distributes data evenly to extend the life of the memory.

In addition, the eMMC memory can be operated in pSLC mode. This mode is not enabled in the default device. Switching to pSLC function reduces the usable memory capacity, but at the same time significantly increases the memory life in terms of write cycles. If you would like to use this feature, please contact the product management at Kendrion

## 6.5 Temperature sensor

The temperature sensor integrated in the CPU module enables continuous detection of the internal processor temperature. The temperature can be read out both via the device's web interface and via the system functions provided in the user program. The determined values provide important indicators for the thermal load of the system, the actual utilization and the effectiveness of ventilation.

The maximum specified operating temperature of the CPU is in the range of **75 °C to 85 °C**, depending on the device variant. Values above this range can reduce the service life of the electronics or lead to unstable operating behavior. The temperature development is significantly influenced by:

- the type of device and the actual hardware configuration,
- the presence or absence of air circulation in the control cabinet,
- the external ambient or ambient air temperature,
- the current load on the system (e.g. CPU load due to CODESYS applications or I/O activity).

For safe and standard-compliant continuous operation, it is imperative that the temperature is regularly monitored in the user program. If a defined limit value is exceeded, a corresponding message must be triggered. A staged response is recommended:

1. **Alert** when the temperature falls below a predefined threshold but enters a critical range.
2. **Error message or emergency response** when the maximum permissible value is exceeded (e.g. controlled reduction of the load, activation of external fans or shutdown of individual functions).

The inclusion of an optional FIO/Econo fan with EMV mounting plate can demonstrably reduce CPU temperature, contributing to more stable operation and extended service life.

## 6.6 Expansion via USB adapter

RS-232, RS-485, RS-422

The Econo/FIO Controller 228/328 series of devices can be equipped with additional serial interfaces via USB interfaces. The driver for the FTDI chipset, which is used in many USB to serial converters, is built into the device's operating system.

A USB converter with FTDI chipset FT232R is automatically detected and is then available via an entry in the registry.

### Using the new interface in CODESYS

The SysLibCom library is available in CODESYS for using the new serial interface. Before use, this library must be added to the project with the library manager.

### Commands of the SysLibCom Library (excerpt)

Open Port: SysComOpen

Send data: SysComWrite

Read Data: SysComRead

Close Port: SysComClose

The first serial port added is listed as COM 3 in the system by default.



#### Information

The company FTDI Chip offers various converters in different designs. Further information at:  
<http://www.ftdichip.com>

## 6.7 USB Update Functions

You can use the USB update functions to load adapted system configurations, install the CODESYS boot application on the device or perform a complete system update. A template for the system configuration and the loading of a CODESYS boot application can be found on the Internet in our product finder.

	<b>NOTE</b>
	<p><b><i>Incorrect or faulty update</i></b>  <i>Control failure and data loss</i></p> <ul style="list-style-type: none"> <li>⇒ Make sure that you are using the correct update file for your device with correct system configuration for an update.</li> <li>⇒ For a USB update, use a USB stick with SLC or pSLC technology in industrial design, a status LED in the USB stick simplifies the tracking of the update process.</li> </ul>

### Updating the system

A system update is provided as an archive file upon request. This is to be unzipped onto a USB stick. The update can also update the system configuration.

### System Configuration Update

The system configuration update is configured in the sysconf file. This must be located in the root directory of the USB stick. Since the sysconf file is just a text file with special formatting, it can be edited with any text editor. The file contains sections [section] and keys, similar to the structure of a \*.ini file. System configurations can also be carried out during operation. If a stick with the file "sysconf" is inserted, the running CODESYS application is terminated and the update is processed. The CODESYS application is then started again.

## 6.8 Device Description

For all variants of the Econo with the iMX6 processor system, the device description "ContollerES6" is used. This can be downloaded from the device, as well as the device description for the optionally integrated 4DI/4DO in the web configurator in the "Download" menu.

Device version	Device Id	Device Name
Econo XX6	64	FIO ControllerES6

# 7 Appendix

## 7.1 Dimensions

### 7.1.1 Controller / Econo

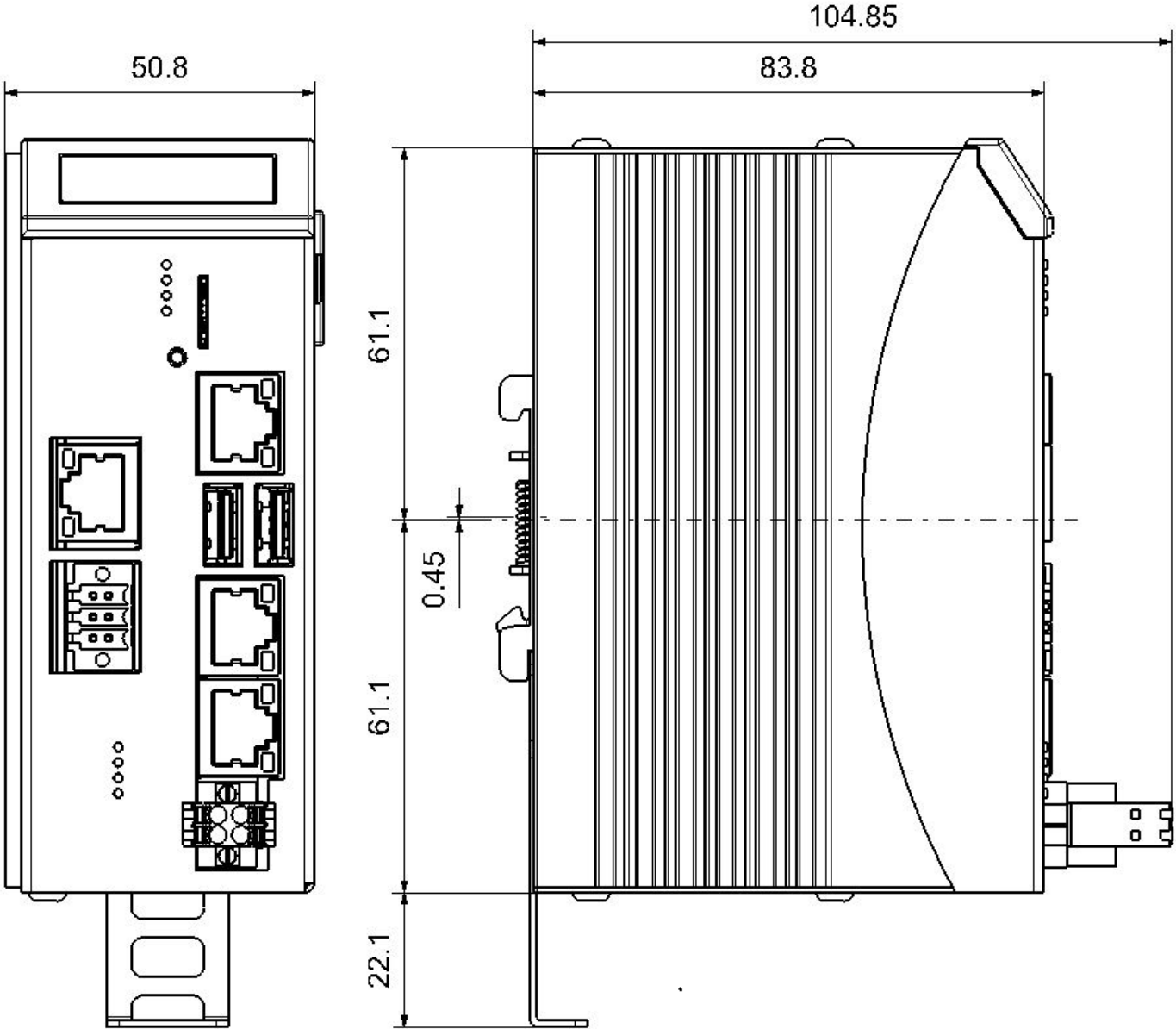

7.1.2 Controller / Econo with fan and EMC terminals

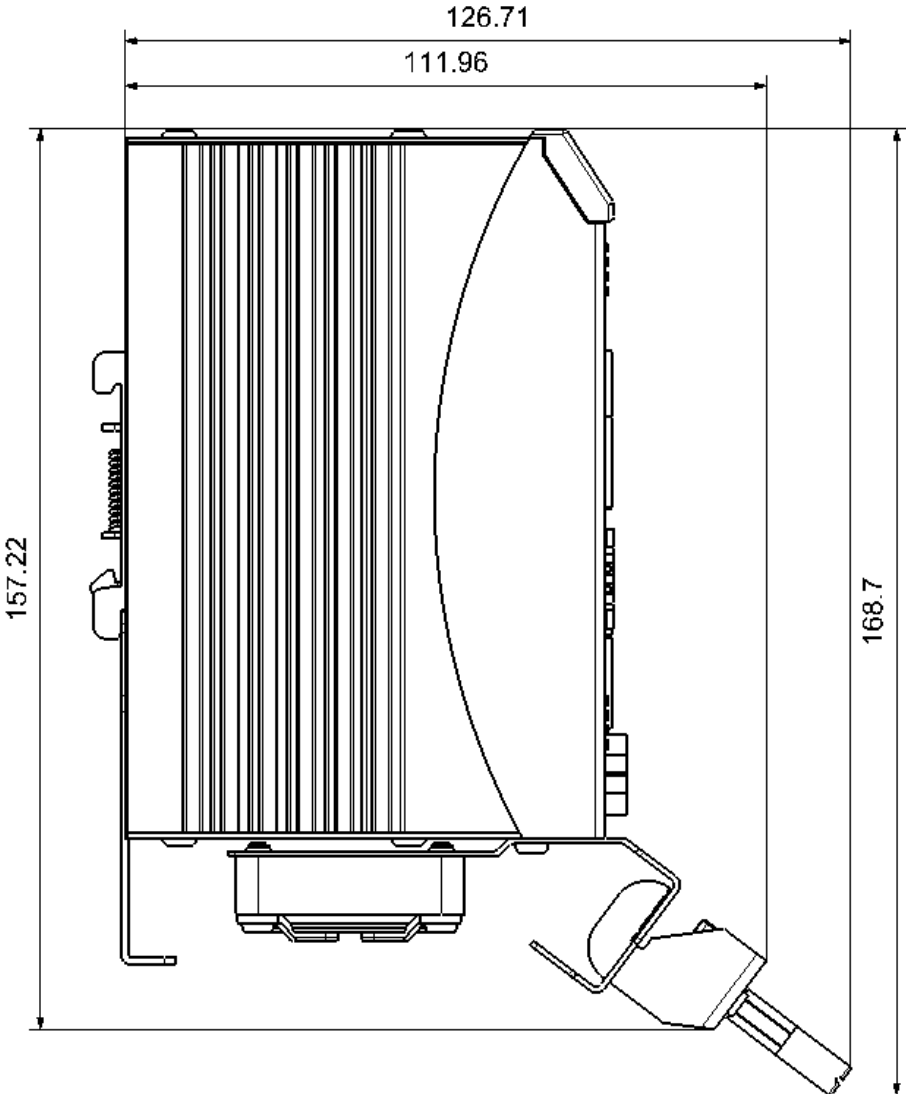

## 7.2 Standards and limit values complied with

### 7.2.1 Safety-related standards and guidelines

#### Safety-related standards and guidelines

DIN EN 61131-2:2008 Programmable logic controllers – Part 2: Equipment requirements and tests

### 7.2.2 Cyber Security

#### Safety-related standards and guidelines

REGULATION (EU) 2024/2847 OF THE EUROPEAN PARLIAMENT AND OF THE COUNCIL of 23 October 2024 on horizontal cybersecurity requirements for products with digital elements and amending Regulations (EU) No 168/2013 and (EU) 2019/1020 and Directive (EU) 2020/1828 (Cyber Resilience Regulation)

### 7.2.3 EMC

#### EMC

##### Interference emission

Fachgrundnorm DIN EN 61000-6-4:2007

Electromagnetic compatibility (EMC) – Part 6-4: Technical principles – Interference emission for industrial sectors

Product norm DIN EN 61131-2:2008-04

Programmable logic controllers – Part 2: Equipment requirements and tests

##### RF Emission (Radiated)

##### LF-Störaussendung (Conducted)

##### Immunity to interference

Fachgrundnorm DIN EN 61000-6-2:2011-06

Electromagnetic compatibility (EMC) – Part 6-2: Technical principles – Immunity for industrial sectors

Product norm DIN EN 61131-2:2008-04

Programmable logic controllers – Part 2: Equipment requirements and tests

##### RF Immunity

##### ESD

##### Burst

##### Surge

##### Inflow

### 7.2.4 Material Compliance

#### RoHS

The product complies with the listed restrictions for substances according to EU Directive 2011/65/EU, Delegated Directive 2015/863/EU and Electrical Substances Ordinance (ElektroStoffV).

### 7.2.5 Permissible environmental conditions

#### Permissible environmental conditions

<b>Storage and transport</b>	
<b>Temperature</b>	-25...+70 °C
<b>relative humidity</b>	5% to 95% at 25°C (no condensation)
<b>Vibrations</b>	5 to 9 Hz: +/-3.5 mm, 9 to 150 Hz: 9.8 m/s <sup>2</sup> (1g)
<b>Shock</b>	150 m/s <sup>2</sup> , 11 ms (15g)
<b>The establishment</b>	
<b>Location</b>	Use only indoors, control cabinets
<b>Altitude</b>	max. 2000m
<b>Ambient temperature</b>	0°C... +40°C, in vertical installation position 0°C... +55°C, with fan and any installation position
<b>relative humidity</b>	5% to 95% at 25°C (no condensation)
<b>Vibrations</b>	5 to 9 Hz: +/-3.5 mm, 9 to 150 Hz: 9.8 m/s <sup>2</sup> (1g)
<b>Shock</b>	150 m/s <sup>2</sup> , 11 ms (15g)

## 7.3 Policies and Statements

### 7.3.1 Conformity marking

The EC declarations of conformity and the associated documentation are kept available to the competent authorities in accordance with the above-mentioned EC Directive.

Kendrion declares that this product meets the essential requirements of Regulation (EU) 2024/2847 (Cyber Resilience Regulation).

Please contact support if necessary.



### 7.3.2 RoHS

The **RoHS Directive** (Restriction of Hazardous Substances) is a central regulation of the European Union that regulates the use of certain hazardous substances in electrical and electronic equipment. The aim of the Directive is to minimise the environmental impact of these devices and to promote safe recycling and disposal.

This product meets the requirements of the RoHS Directive (2011/65/EU and 2015/863/EU) and does not contain any hazardous substances that exceed the set limits.

RoHS compliance demonstrates our commitment to sustainability, environmental protection and regulatory compliance.

RoHS ✓

Complies with RoHS Directive 2011/65/EU and Delegated Directive 2015/863/EU on the Restriction of the Use of Certain Hazardous Substances in Electrical and Electronic Equipment

Exceptions used according to EU Directive 2011/65/EU Annex III, 6 a –c

## 7.4 Approvals

The following approvals have been granted for the Econo 206:

## 7.5 Ordering details

### 7.5.1 Basic Units

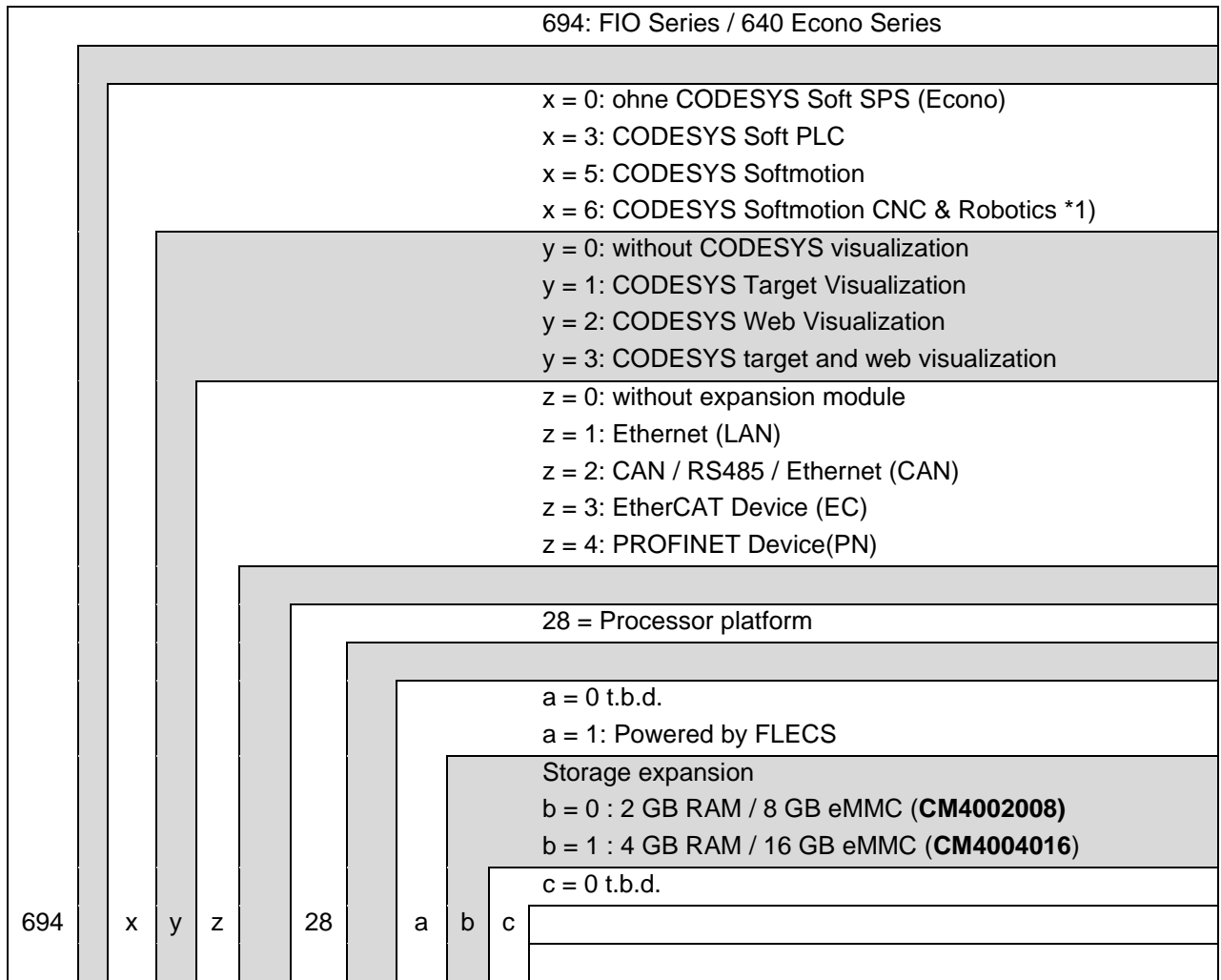

\*1) Please note that FIO controllers with the SM CNC software variant are compatible with the SM CNC software variant in accordance with point 2D002 of the Dual-Use Goods List Appendix 1 Cat. 2 are subject to approval for export from the EU (e.g. as a spare part). Find out about the licensing procedure at the responsible office (Germany: Federal Office of Economics and Export Control). If the device is installed in a machine with the SM CNC software version, the machine classification automatically applies.

An up-to-date overview of the available combinations can be found on the Internet in our product finder at: <https://www.kendrion.com/de/produktfinder/gruppe/modulare-sps>

Other combinations on request.

## 7.5.2 Basic Units

**Technical data****FIO Controller 228****694**

Compact PLC  
 Quad -core ARM Cortex A72 (4 x 1.5 GHz)  
 2GB DDR4L / 256 Byte EEPROM, 128 kB Remanent Memory, eMMC Memory 8 GByte  
 Operating System: Linux PREEMPT RT  
 CODESYS Soft PLC, CODESYS TargetVisu, CODESYS WebVisu, MotionEtherCAT MainDevice,  
 OPC UA, Modbus TCP, EtherCAT outPower supply designed for control tasks, 24 V DC (-20% +25%)

**FIO Controller 328 WV SM Ethernet****694 631 28 000**

Kompakt SPS  
 Quad -core ARM Cortex A72 (4 x 1,5 GHz)  
 2GB DDR4L / 256 Byte EEPROM, 128 kB Remanenter Speicher, eMMC Speicher 8 GByte  
 Betriebssystem: Linux PREEMPT RT CODESYS Soft SPS, CODESYS TargetVisu, CODESYS  
 WebVisu, Motion  
 EtherCAT MainDevice, EtherNet/IP Scanner / Adapter, PROFINET  
 Modbus TCP client/server, power supply designed for control tasks, 24 V DC (-20% +25%)

**FIO Controller 328 CAN WV SM****694 632 28 000**

Kompakt SPS  
 Quad -core ARM Cortex A72 (4 x 1,5 GHz)  
 2GB DDR4L / 256 Byte EEPROM, 128 kB Remanenter Speicher, eMMC Speicher 8 GByte  
 Betriebssystem: Linux PREEMPT RT CODESYS Soft SPS, CODESYS TargetVisu, CODESYS  
 WebVisu, Motion  
 EtherCAT MainDevice, EtherNet/IP Scanner / Adapter, PROFINET  
 Modbus TCP Client/Server, power supply designed for control tasks, 24 V DC (-20% +25%)

**FIO Controller 328 EtherCAT****694 633 28 000**

Kompakt SPS  
 Quad -core ARM Cortex A72 (4 x 1,5 GHz)  
 2GB DDR4L / 256 Byte EEPROM, 128 kB Remanenter Speicher, eMMC Speicher 8 GByte  
 Betriebssystem: Linux PREEMPT RT CODESYS Soft SPS, CODESYS TargetVisu, CODESYS  
 WebVisu, Motion  
 EtherCAT MainDevice, EtherNet/IP Scanner / Adapter, PROFINET  
 Modbus TCP Client/Server, power supply designed for control tasks, 24 V DC (-20% +25%)

**Econo 328****640 001 28 000**

Embedded PC, Edge Computing  
 Quad -core ARM Cortex A72 (4 x 1.5 GHz)  
 Operating System: Linux PREEMPT RT  
 2 x Ethernet 1000 Mbit – RJ45 (switched), 1 x Ethernet 1000 Mbit  
 2 x Ethernet 100 Mbit – RJ45 (switched) 2x USB3.0 / 1x USB2.0 / 1x HDMINetched adapter  
 designed for control tasks, 9 ... 28.8 V DC, Mini UPS



\* Please note that FIO controllers with the SM CNC software variant in accordance with point 2D002 of the Dual-Use Goods List Appendix 1 Cat. 2 are subject to approval for export from the EU (e.g. as a spare part). Find out about the licensing procedure at the responsible office (Germany: Federal Office of Economics and Export Control). If the device is installed in a machine with the SM CNC software version, the machine classification automatically applies.

### 7.5.3 Accessories

Technical data	
<b>FIO Controller / Econo Fan with EMC Mounting Plate 1 x 14 mm, 2 x 8 mm)</b>	<b>694 413 01</b>
<p>Fan 40 x 40 with connection cables, finger guard and mounting material</p> <p>The mounting plate is mounted directly under the device using the screws supplied. The power supply is via a terminal in the front</p> <p>Shield Terminal Block 1 x 14 mm</p> <p>Shield Terminal Block 2 x 8 mm</p> <p>The shield terminal blocks are mounted directly on the conductive carrier plate by simply swinging open.</p>	



Kendrion Kuhnke Automation GmbH  
Industrial Control Systems

---

Lütjenburger Str. 101  
23714 Malente

Phone: +49 4523 402 0  
Fax: +49 4523 402 201

---

[sales-ics@kendrion.com](mailto:sales-ics@kendrion.com)  
[www.kendrion.com](http://www.kendrion.com)