

### SLIM COLLECTION

PWM module for electromagnetic devices



34 x0125C0x

The PWM module provides optimized control of inductive loads such as electromagnetic brakes, clutches and valves. The electronic module uses pulse-width modulation to keep the voltage supplied to the electromagnetic device at a constant level over a wide input voltage range.

A higher voltage (overexcitation voltage) is applied for a limited period of time to ensure fast and powerful switching when the load is turned on. The electronic module then reduces the power supply to constant holding voltage. A 30% reduction provides energy savings of 50%. Lower intrinsic heating of the load extends the operating temperature range.

The module is very compact thanks to the use of state-of-the-art microelectronics and power electronics components. Overexcitation time and holding voltage can be factory-programmed to meet specific customer requirements.

### Technical specifications

Functional principle		controlled pulse-width modulation (PWM)			
Fast turn-off		type-specific; through internal voltage detection			
Pulse-width modulation (PWM)		Overexcitation 24V ± 10% for 200 ms then switching to holding voltage (see table)	other PWM settings upon request (10% to 70%)		
Ambient temperature		(°C)	-20 ... 80	derating as specified*	
Max. switching frequency		(h <sup>-1</sup> )	4000**	From an ambient temperature of 60 °C 2500 ** per hour	
Input voltage range		(VDC)	24 V...48 V	±20%	
Overexcitation (OE) voltage		(VDC)	input voltage (up to -10%) or max. 24V ±10% controlled voltage		
Overexcitation (OE) time		(ms)	200 ms ±10%***	other time settings upon request	
Voltage control through PWM, base frequency		(Hz)	17 KHz ±5%	other frequency settings upon request	
Type	Rated input voltage U <sub>1</sub> (tol.: ±20%)	Max. output current OE/holding current (ADC)*	Fast turn-off	Holding voltage ±5% at RT	Connections / Installation
34 10125C01	24 – 48 V	4 / 2	no	16.8 V	Input = 2 wires 0.5 mm <sup>2</sup> , fine-wire type to UL1015 (AWG20) Output = 2 terminals 0.2 mm <sup>2</sup> to 0.75 mm <sup>2</sup> (wire type 1) Central bore for screw fixing M4 Dmax. 4 mm***** Adhesive pad
34 70125C01	24 – 48 V	4 / 2	yes	16.8 V	
34 10125C02	24 – 48 V	4 / 2	no	12 V	
34 70125C02	24 – 48 V	4 / 2	yes	12 V	

\* See derating diagram (max. current load at ambient temperature)

\*\* The maximum switching frequency of 4000 h<sup>-1</sup> operations (or 2500 h<sup>-1</sup> from 60 °C ambient temperature) are validated with the brake KS 11016A01 (U<sub>nen</sub> = 24VDC, I<sub>nen</sub> = 1.65A) and KS 10019A00 (U<sub>nen</sub> = 24VDC, I<sub>nen</sub> = 2.36A). With smaller loads, significantly larger switching numbers are also possible. Consult the manufacturer (Kendrion) for applications with higher switching frequencies.

\*\*\* Overexcitation time may be different at extremely high or low ambient temperatures

\*\*\*\* Max. torque 0.6 N

### CE

#### EMC Directive 2014/30/EU:

Compliance with the following standards is confirmed:

EN 50081-2 (Emission):

EN 55011 (VDE 0875, part 11, 2011)

Group 1, Class A conducted interference

Group 1, Class B radiated interference

EN 61000-6-2 (Immunity):

EN 61000-4-3 (2011)

EN 61000-4-4 (2013) severity level 3

EN 61000-4-5 (2015) severity level 3

#### Low Voltage Directive 2014/35/EU:

Compliance with the following standards is confirmed:

HD 625.1S1 (2009)

(VDE 0110) insulation coordination, EN 60529 (2014) IP00

#### Machinery Directive 2006/42/EC:

The products are considered components in the sense of Machinery Directive 2006/42/EC and must not be put into service until the machinery in which they are incorporated has been declared in conformity with the provisions of the EC Directives.

#### ROHS Directive 2011/65/EU:

We hereby declare that the above-mentioned products comply with the requirements of the RoHS Directive 2011/65/EU on the restriction of the usage of certain hazardous substances in electrical and electronic equipment, assigned to equipment category 11.

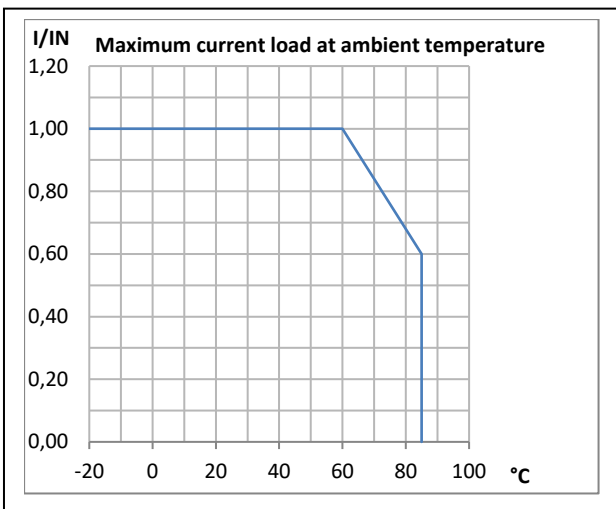
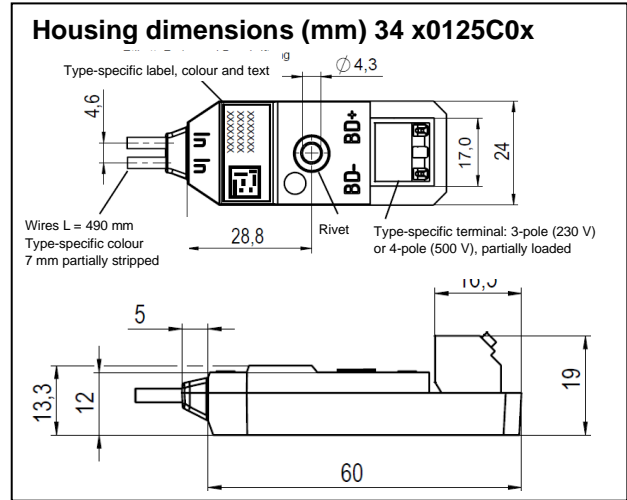
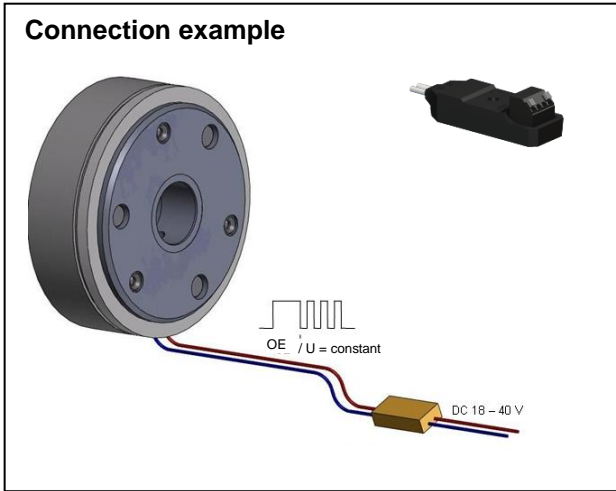

### PWM module types

Type	Voltage $U_N$	Holding voltage	Comments
34 x0125C00	24 V	10 – 90%	factory-programmable
34 x0125C01	24 V	16.8 V	
34 x0125C02	24 V	12 V	

### Connection and operation

#### 34 x0125C0x

The PWM module keeps the control voltage supplied to the electromagnetic device at a constant level over a wide input voltage range. When the device is turned on, a high voltage is applied on a time-controlled basis to ensure fast and powerful switching. Depending on the specific application, the controlled holding voltage applied after this initial phase can be factory-set to between 10 and 90% of the rated voltage to ensure ideal operating conditions. This solution offers substantial energy savings along with a wider operating temperature range thanks to reduced intrinsic heating.

#### Notes for UL Compliance

- The module must be installed in the motor terminal box or in the control cabinet.
- A pre-fuse corresponding to the cross-section of the connected brake line must be provided, but max. 5A.
- The product is intended to be used under pollution degree 2.

#### Protection:

IP 00 to EN 60529

Subject to change without notice.

**Kendrion (Villingen) GmbH**  
Wilhelm-Binder-Str. 4-6  
78048 Villingen-Schwenningen  
Germany

Tel. +49 (0)7721 877-1417  
Fax +49 (0)7721 877-1462  
E-mail sales-ids@kendrion.com  
[www.kendrion.com](http://www.kendrion.com)

### Prescribed wire diameters for circuit board terminal

Wire type 1	single-wire
Cross-section [mm <sup>2</sup> ]	0.2 – 0.75
Cross-section [AWG]	24 – 18
Wire type 2	fine-wire
Cross-section [mm <sup>2</sup> ]	0.2 – 0.75
Cross-section [AWG]	24 – 18
Wire type 3	fine-wire with wire end ferrule
Cross-section [mm <sup>2</sup> ]	0.25 – 0.34

### Connections for 34 x0125C01

Colour	Identification on housing
U <sub>in</sub> red	BA1
U <sub>in</sub> blue	BA2
U <sub>out</sub>	BD1
U <sub>out</sub>	BD2