



User Guide

Vico MT 727, Vico MT 1027, Vico MT 1527
Multi-touch Panel with CODESYS HMI
Web Terminal

E 863 GB

01/10/2021

Table of Contents

1 Preface	5
1.1 Legal Notice.....	5
1.1.1 Version Details	5
1.2 About this Manual	5
1.2.1 Limitation of Liability	5
1.2.2 Terms of Delivery	5
1.2.3 Copyright	6
1.2.4 Software licences	6
1.2.5 Warranty	6
1.3 Reliability, Safety	7
1.3.1 Applicability	7
1.3.2 Target Group of the Instruction Manual	7
1.3.3 Intended Use	7
1.3.4 Reliability	7
1.3.5 Hazard and Other Warnings	8
1.3.6 Other Notices	8
1.3.7 Electrical Safety.....	8
1.3.8 IT Security	10
1.3.9 Electromagnetic Compatibility.....	10
2 Product Description	12
2.1 General Description	12
2.1.1 Software Releases	12
2.1.2 Hardware Versions.....	13
2.2 Application	14
2.2.1 Intended Use	14
2.2.2 Foreseeable Misuse	14
2.3 Technical Data.....	15
2.3.1 Vico MT	15
2.3.2 Dimensions.....	16
3 Construction and Functionality	17
3.1 Brief Description	17
3.2 Overview.....	17
3.3 Labelling and Identification	18
3.3.1 Name Plate.....	18
3.3.2 Name Plate Details	18
3.3.3 Serial Number	19
3.4 Contents of Package	19
3.5 Transport and Storage.....	20
3.6 Interfaces	21
3.6.1 Power Supply "24VDC", (X1)	22
3.6.2 Operative Earth (X11)	22
3.6.3 USB 2.0 host "USB1", "USB2" (X9)	23
3.6.4 Ethernet "NET1" (X5)	24
3.6.5 Ethernet "NET2" (X6)	24
3.6.6 Serial Communication RS-232 "X12"	25
3.6.7 MicroSD Card (X3).....	26
3.7 Indicators and Controls.....	27
3.7.1 Ethernet "NET1" (X5), "NET2" (X6)	27

3.8	Front	27
3.8.1	Screen	27
3.8.2	Backlight	27
3.8.3	Touch	27
4	Installation and Operation	28
4.1	Mechanical Installation	28
4.1.1	Mounting Position	28
4.1.2	Front Panel Opening	29
4.2	Electrical Installation	31
4.2.1	Operative Earth	31
4.2.2	System Power Supply	31
4.3	Putting into Service	33
4.3.1	General Start-up Information	33
4.3.2	Start-up Prerequisites	33
4.3.3	Turning on the Unit	33
4.3.4	Turning off the Unit	33
4.4	IT Security	34
4.5	Configuration	35
4.6	Diagnosis	36
4.7	Table of Faults	36
4.8	Maintenance / Servicing	37
4.8.1	General	37
4.8.2	Servicing	37
4.8.3	Preventive Maintenance	37
4.9	Life Expectancy	38
4.9.1	Repairs / Customer Service	38
4.9.2	Warranty	38
4.9.3	Taking out of Service / Disposal	38
5	System Configuration	39
5.1	Accessing the System Configuration	39
5.2	Functions and Settings	39
5.2.1	Header	39
5.2.2	Network	39
5.2.3	Display	40
5.2.4	Time Date	40
5.2.5	Disks	40
5.2.6	Fonts	40
5.2.7	Access SystemConfig	40
5.2.8	Access FTP Server	40
5.2.9	Firewall (iptables)	40
5.2.10	OpenVPN	40
5.2.11	System Info & Access	40
5.2.12	Resources Monitor	40
5.2.13	Process List	40
5.2.14	Log	41
5.2.15	Log Persistent	41
5.2.16	Terminal	41
5.2.17	Boot Script	41
5.2.18	Backup/Restore	41
5.2.19	System Backup/Restore (Live System)	41

5.2.20 Browser Settings	41
5.2.21 Browser Log	41
5.3 System Functions	42
5.3.1 Keyboard	42
5.3.2 Mouse Support.....	42
5.3.3 Run Linux Scripts Automatically.....	42
5.3.4 Configuring the Web Browser	42
5.3.5 Installing Fonts	42
5.3.6 Configuring the Network.....	42
6 Appendix.....	43
6.1 Software Copyrights	43
6.2 Drawings.....	44
6.2.1 Dimensions of Vico MT 727	44
6.2.2 Installation Opening of Vico MT 727	45
6.2.3 Font View of Vico MT 727	45
6.2.4 Dimensions of Vico MT 1027	46
6.2.5 Installation Opening of Vico MT 1027	47
6.2.6 Front View of Vico MT 1027	47
6.2.7 Vico MT1527	48
6.2.8 Installation Opening of Vico MT1527	49
6.2.9 Front View of Vico MT1527	49
6.3 Applicable Standards and Limits	50
6.3.1 EMC Standards	50
6.3.2 Admissible Ambient Conditions.....	50
6.4 Regulations and Declarations.....	51
6.4.1 Mark of Conformity	51
6.5 Approvals.....	51
6.6 Order Specifications	52
6.6.1 Basic Units	52
6.6.2 Accessories	53

1 Preface

1.1 Legal Notice

Contact Details

Kendrion Kuhnke Automation GmbH

Industrial Control Systems

Lütjenburger Straße 101

D-23714 Malente, Germany

Tel. +49 4523 402-0

Fax +49 4523 402-201

Email sales-ics@kendrion.com

Email Support controltechnology-ics@kendrion.com

Internet www.kendrion.com

1.1.1 Version Details

Modification History

Date	Comments / Modifications
11.05.2021	Preliminary version
01.10.2021	Original version
22.12.2021	Corrections and enhancements

1.2 About this Manual

This technical information is primarily directed to system designers, project engineers and device developers. It does not contain any availability information. We reserve the rights for errors, omissions and modifications. Pictures are similar.

1.2.1 Limitation of Liability

Specifications are for description only and are not to be understood as guaranteed product properties in a legal sense. Exact properties and characteristics shall be agreed in the specific contract. Claims for damages against us - on whatever grounds - are excluded, except in instances of deliberate intent or gross negligence on our part.

1.2.2 Terms of Delivery

The general conditions of sales and service of Kendrion Kuhnke Automation GmbH shall apply.

1.2.3 Copyright

© Kendrion Kuhnke Automation GmbH

This instruction manual is proprietary and protected by copyright.

No part of this document may be reproduced or copied in any way or by any means except expressly permitted in writing by Kendrion Kuhnke Automation GmbH.

Microsoft®, Windows® and the Windows® logo are registered trademarks of Microsoft Corp. in the USA and other countries.

EtherCAT® is a registered trademark and patented technology, licenced by Beckhoff Automation GmbH, Germany.

Further information about the PLCopen organisation is available at www.plcopen.org. CiA® and CANopen® are registered Community trademarks of CAN in Automation e.V.

CODESYS® is a product of CODESYS GmbH.

i.MX8 is a registered trademark of Freescale

ARM ® and Cortex ® are registered trademarks of ARM Limited.

Modbus® is a registered trademark of the Modbus-IDA Organisation.

The companies mentioned herein own the property rights in their company, product and trade names.

1.2.4 Software licences

The units' firmware contains open source software. Some of this software is subject to the following and other open source licences:

- GNU General Public License (GPL)
- MIT License
- BSD Zero Clause License
- GNU Lesser General Public License (LGPL)
- Mozilla Public License (MPL)
- FreeType License (FTL)

Within three years of delivery, customers may buy the source code of the free software from Kendrion Kuhnke's product management at net costs.

CODESYS

Like all other CODESYS products, the CODESYS software version installed in this system is subject to CODESYS GmbH's end user licence agreement (EULA) as published on the CODESYS website.

1.2.5 Warranty

Warranty is subject to the provisions of the conditions of sale of Kendrion Kuhnke Automation GmbH or any contractual agreements between the parties.

1.3 Reliability, Safety

This chapter just summarises the most important safety instructions and notices, which you will find again in the applicable chapters. Carefully read and respect the safety guidelines as they will provide protection against personal injury and prevent material damage to the units.

1.3.1 Applicability

For reasons of personal safety and to avoid material damages when working with or handling this Kuhnke product, you are advised to take heed of the notes and information contained in this instruction manual.

1.3.2 Target Group of the Instruction Manual

This instruction manual contains all information necessary for the use of the described product (control unit, control terminal, software, etc.) according to instructions. It is written for design, project planning, servicing and commissioning experts. For proper understanding and error-free application of technical descriptions, instructions for use and particularly of notes of danger and warning, extensive knowledge of automation technology is compulsory.

1.3.3 Intended Use

Kendrion's products are designed, developed and manufactured for standard industrial use. They must not be used for any other purposes than the ones specified in the catalogue or the associated technical documentation. Proper and safe operation depends on the products being transported, stored, lined up, mounted, installed, put into service, operated, and serviced correctly. Ambient conditions must be within the admissible limits. Notes and information in the associated documentation apply at all times. For details on how to use this product as intended, refer to chapter 2.2 Application, Intended Use.

1.3.4 Reliability

Reliability of products is brought to the highest possible standards by extensive and cost-effective means in their design and manufacture.

These include:

- selecting high-quality components,
- quality agreements with our suppliers,
- actions to avoid static charges when handling MOS circuits,
- worst case planning and design of all circuits,
- visual inspections at various stages of fabrication,
- computer-aided tests of all assemblies and their interaction in the circuit,
- statistical assessment of the quality of fabrication and of all returned goods for the immediate taking of appropriate corrective actions.

1.3.5 Hazard and Other Warnings

Despite the actions described hereunder, the occurrence of faults or errors in electronic control units - even if most highly improbable - must be taken into consideration.





Please pay particular attention to the additional notices which we have marked by symbols throughout this instruction manual. While some of these notices make you aware of possible dangers, others are intended as a means of orientation. They are described further down below in descending order of importance.

Every alert and hazard warning is made up as follows:

Type and source of risk

Potential consequences of non-observance

⇒ Preventive measures

	<p>DANGER</p> <p><i>A DANGER warning makes you aware of an immediately hazardous situation which WILL cause a serious or fatal accident if not observed.</i></p>
	<p>WARNING</p> <p><i>A WARNING makes you aware of a potentially hazardous situation which MAY cause a serious or fatal accident or damage to this or other devices if not observed.</i></p>
	<p>CAUTION</p> <p><i>A CAUTION alert makes you aware of a potentially hazardous situation which MAY cause an accident or damage to this or other devices if not observed.</i></p>
	<p>NOTE</p> <p><i>A NOTE makes you aware of a potentially hazardous situation which MAY cause damage to this or other devices if not observed.</i></p>

1.3.6 Other Notices

	<p>Information</p> <p><i>This symbol draws your attention to additional information concerning the use of the described product. This may include cross references to information found elsewhere (e.g. in other manuals).</i></p>
---	---

1.3.7 Electrical Safety

Our products normally become part of larger systems or installations. The information below is intended to help you integrate the product into its environment without dangers to humans or material/equipment.

	<p>DANGER</p> <p>Non-observance of the instruction manual</p> <p><i>Measures for the prevention of dangerous faults or errors may be rendered ineffective or new hazard sources created.</i></p> <p>⇒ <i>Thoroughly read the instruction manual</i></p>
---	---

	⇒ <i>Take particular heed of the hazard warnings</i>
--	--

	Information
	<i>To achieve a high degree of conceptual safety in planning and installing an electronic controller, it is essential to exactly follow the instructions given in the manual because wrong handling could lead to rendering measures against dangers ineffective or to creating additional dangers.</i>

Project Planning

- 24 VDC power supply: generate as electrically safely separated low voltage. Suitable devices include split-winding transformers built in compliance with European Standard EN 60742 (corresponds to VDE 0551).
- Power breakdowns or power fades: the program structure is to ensure that a defined state at restart excludes all dangerous states.
- Emergency-off installations must comply with EN 60204/IEC 204 (VDE 0113). They must be operative at any time.
- Safety and precautions regulations for qualified applications have to be complied with.
- Please pay particular attention to the notices of warning which, at relevant places, will make you aware of possible sources of dangerous mistakes or faults.
- Relevant standards and VDE regulations are to be complied with in every case.
- Control elements are to be installed in such a way as to exclude unintended operation.
- Lay control cables such that interference (inductive or capacitive) is excluded if this interference could influence controller operation or its functionality.

Maintenance and Servicing

- Precautions regulation BGV A3 (Elektrische Anlagen und Betriebsmittel) to be observed when measuring or checking a controller after power-up. This applies to section 8 (Admissible deviations when working on parts) in particular.
- Only use parts approved of by Kendrion KUHNKE. Only genuine Kendrion KUHNKE modules may be used in modular controllers.
- Modular systems: always plug or unplug modules in a power-down state. You may otherwise damage the modules or (possibly not immediately recognisably!) inhibit their functionality.
- Always dispose of (rechargeable) batteries as hazardous waste.

1.3.8 IT Security

Kendrion Kuhnke products are designed for use in closed (private) industrial network environments.

In case such industrial networks are open to public access (e.g. via fully accessible network interfaces) or otherwise externally accessible (e.g. via data links and public (Internet) traffic), the integrator and operator must take appropriate organisational and technical precautions to protect the in-house network and ensure IT security.

	Information
	<p><i>To find information about how to safely operate equipment, systems and networks, please refer to the texts published by BSI (Federal Office for Information Security), other publicly available sources and IEC 62443.</i></p>

1.3.9 Electromagnetic Compatibility

Definition

Electromagnetic compatibility is the ability of a device to function satisfactorily in its electromagnetic environment without itself causing any electromagnetic interference that would be intolerable to other devices in this environment.

Of all known phenomena of electromagnetic noise, only a certain range occurs at the location of a given device. It is defined in the relevant product standards.

The design and immunity to interference of programmable logic controllers are internationally governed by standard

IEC 61131-2 which, in Europe, has been the basis for European Standard EN 61131-2.

	Information
	<p><i>Refer to IEC 61131-4, User's Guideline, for general installation instructions to be complied with to ensure that hardware interface factors and the ensuing noise voltages are limited to tolerable levels.</i></p>

Interference Emission

Interfering emission of electromagnetic fields, HF
compliant to EN 55011, limiting value class A, Group 1

	Information
	<p><i>If the controller is designed for use in residential areas, high-frequency emissions must comply with limiting value class B as described in EN 55011. Fitting the controller into earthed metal cabinets and installing filters in the supply lines and other means may produce a shielding compliant to the above standard.</i></p>

General Notes on Installation

As component parts of machines, facilities and systems, electronic control systems must comply with valid rules and regulations, depending on their field of application.

General requirements concerning the electrical equipment of machines and aiming at the safety of these machines are contained in Part 1 of European Standard EN 60204 (same as VDE 0113).

Electrical Immission Safeguard

To eliminate electromagnetic interference, connect the control system to the protective earth conductor.
Practice best cable routing.

Cable Routing and Wiring

Keep power circuits separate from control circuits:

- DC voltages 60 V ... 400 V
- AC voltages 25 V ... 400 V

Joint laying of control circuits is allowed for:

- shielded data signals
- shielded analogue signals
- unshielded digital I/O lines
- unshielded DC voltages < 60 V
- unshielded AC voltages < 25 V

Location of Installation

Ensure that temperatures, contaminations, impact, vibration or electromagnetic interference are no impediment to the installation.

Temperature

Consider heat sources such as general heating of rooms, sunlight, heat accumulation in assembly rooms or control cabinets.

Contamination

Use suitable casings to avoid possible negative influences due to humidity, corrosive gas, liquid or conducting dust.

Impact and Vibration

Consider possible influences caused by motors, compressors, transfer lines, presses, ramming machines and vehicles.

Electromagnetic Interference

Consider electromagnetic interference from various local sources: motors, switching devices, switching thyristors, radio-controlled devices, welding equipment, arcing, switched-mode power supplies, converters / inverters.

Particular Sources of Interference

Inductive Actuators

Switching off inductances (such as from relays, contactors, solenoids or switching magnets) produces surge voltages. It is necessary to reduce these extra voltages to a minimum.

Reducing elements may be diodes, Z-diodes, varistors or RC elements. Their rating should conform to the specifications provided by the manufacturer or supplier of the actuators.

2 Product Description

2.1 General Description

Vico MT panel series devices are designed for use as a multi-touch control panel in industry and building automation. By default, the panels feature a high-quality, high-resolution display with a large aspect angle and a powerful Quad Core™ Arm® i.MX8 CPU.

The sturdy touch screen resides in an aluminium or stainless steel frame specifically designed for industrial environments. Standard panel models provide IP65 protection at the front and are fit for installation in switching cabinets or control desks.

Their operating system is embedded Linux (Yocto Distribution). The on-board Web Configurator provides access to many different settings for the simple setup of your network, browser look and behaviour, keyboard and language settings, a boot screen or screen saving showing your logo and many other properties.

2.1.1 Software Releases

Various software options or combined software options are available for installation in the devices. Please ask product management for the combination that best fits your needs.

Software Releases		
Option	Identification	Function
CODESYS HMI	HMI	Create modern visualisations of machines and systems straight in the CODESYS Development System and run Vico HMI units to display them for operation or diagnosis. Note that visualisation projects may but need not be linked to the logical application (i.e. your IEC 61131-3 project). Instead, they may connect to several different CODESYS-compatible control units at the same time.
WEB	WEB	The on-board tool kit includes a HTML5 Chromium browser optimised for high performance in combination with a simple and user-friendly configuration plus sophisticated software add-ons for the specific needs of industry users.

2.1.2 Hardware Versions

The unit sells with screens of various sizes but the same control unit at the back.

Front view of Vico MT 727

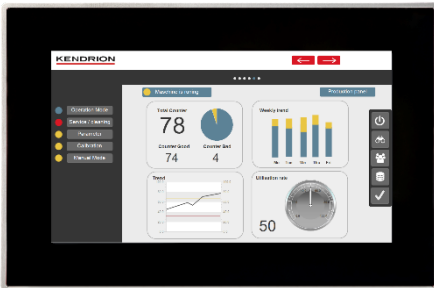

Front view of Vico MT 1027



Front view of Vico MT 1527

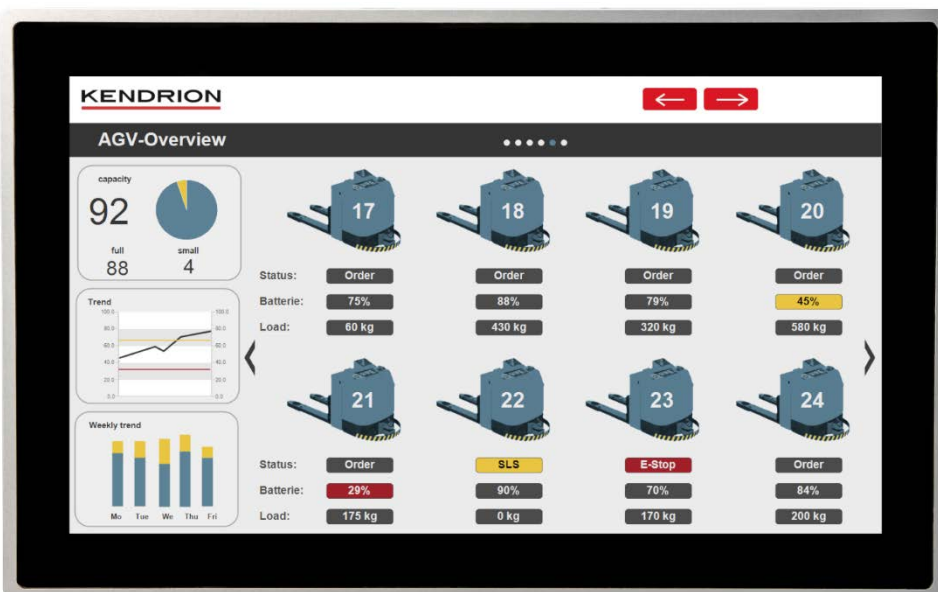

2.2 Application

2.2.1 Intended Use

The panel is designed for on-site use in industrial environments immediately at the machine. It installs in switching cabinets, switching or control panels.

This series provides devices and equipment manufacturing with a visualisation unit for different applications:

Place of installation

If installed in an enclosed space, the unit's front is protected against dust and water. Ingress protection at the back is IP 20 where it should be protected against humidity and dirt separately.

Waste heat develops in the rear part of the unit. Verify that the place of installation is ventilated properly.

	NOTE
	<p>Damage to the unit</p> <p><i>Choosing the wrong place of installation may cause damage to the unit.</i></p> <p>⇒ Check section Technical Data for the admissible ambient conditions and the unit's mounting position.</p>

2.2.2 Foreseeable Misuse

Do not use in explosive atmospheres!

	DANGER
	<p>Do not use in explosive atmospheres!</p> <p><i>Using the unit in explosive atmospheres may cause death or serious personal or property damage.</i></p> <p><i>The unit is neither designed nor approved for use in explosive atmospheres.</i></p>

Do not use in domestic areas!

	WARNING
	<p>This unit is solely designed for use in industrial environments and may provoke radio interference at home. Take the appropriate precautions before using it at home.</p>

Design constraints for high-risk use cases

The product is neither designed nor intended for use in customer systems or together with third-party materials which have been shown to potentially cause fatal or serious personal injury or material or environmental damage if the product fails or produces a fault ("High Risk Use").

High-risk use applications are strictly prohibited.

	DANGER
	<p>Danger caused by malfunctions</p> <p>Fatality, serious personal injury or serious material or environmental damage</p> <p>High-risk use applications are strictly prohibited.</p>

2.3 Technical Data

2.3.1 Vico MT

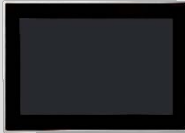
General Specifications			
Product name	Vico MT 727	Vico MT 1027	Vico MT 1527
Screen size / aspect ratio	7" / 17:10	10.1" / 16:10	15.6" / 16:9
			
Resolution	1024 x 600 / (17:10)	1280 x 800 / (16:10)	1366 x 768 / (16:9)
Screen size	154.21 x 86.92 mm	217 x 135.6 mm	344.2 x 193.4 mm
Colours	16.7 million		
Aspect angle	85°/85°/85°/85°	80°/80°/80°/80°	85°/80°/85°/85°
Brightness	450 cd/m ²	420 cd/m ²	400 cd/m ²
Touch screen	Capacitive multi-touch (5 fingers)		
Backlight	White LED, dimmable, life > 50000h (@ 50% brightness)		
Processor	ARM Cortex A53, i.MX8Mmini quad-core CPU, 4x 1.6 GHz		
Clock	Processor resource, no buffer, NTP synchronisation supported		
Software	Operating system: embedded Linux (Yocto Distribution)		
RAM / remanent memory	1 Gbyte DDR4-RAM		
Disk drives	4 Gbyte eMMC ROM, 2 Mbyte NOR flash, 1x MicroSD card slot, up to SDXC		
Networks	1x Ethernet 1 Gbit – RJ45, 1x Ethernet 10/100(1000) Mbit – RJ45		
Ports	2x USB 2.0 host, 1x RS-232 (no electrical insulation)		
Power supply	24 VDC (+20% /- 20%)		
Power consumption	550 mA	580 mA	610 mA
Service conditions			
Mounting position	Vertical; please contact product management for other mounting positions		
Storage temperature	-20 °C...+70 °C		
Operating temperature	0 °C...+55 °C, if installed vertically only		
Rel. humidity	Front: 100% / installation space: 10...95% (@ 25 °C)		
Degree of contamination	Degree 2 to IEC 61010-1		
Working altitude	max. 3000 m a.s.l.		
Front durability	Atmosphere free from corrosive or explosive gases		
Mechanical properties			
Back of housing	IP 20, stainless steel, aluminium sheet housing		
Front panel	IP 65 chemically strengthened glass front resides in milled aluminium frame (with end caps)		
	optically bonded	optically bonded	air gap
Installation	In front panel cutout using quick-mount hardware		
Weight	0.82 kg	1.25 kg	3.4 kg
Dimensions (WxHxD)	200.1 x 131.9 x 47.4 [mm]	264.5 x 187 x 40.9 [mm]	404.5 x 253.5 x 59.4 [mm]
Mounting depth	42.4 mm	35.5 mm	53 mm

2.3.2 Dimensions

Refer to section 8 for exact dimensions

→ 8.2 Dimensions

3 Construction and Functionality

3.1 Brief Description

The panel's powerful processor board with integrated touch screen allows users to run all display and operating functions in a single unit.

It is designed for on-site use immediately at the machine. Mechanical, system and cabinet engineers benefit from the unit's flexibility when designing powerful applications with a small footprint.

3.2 Overview

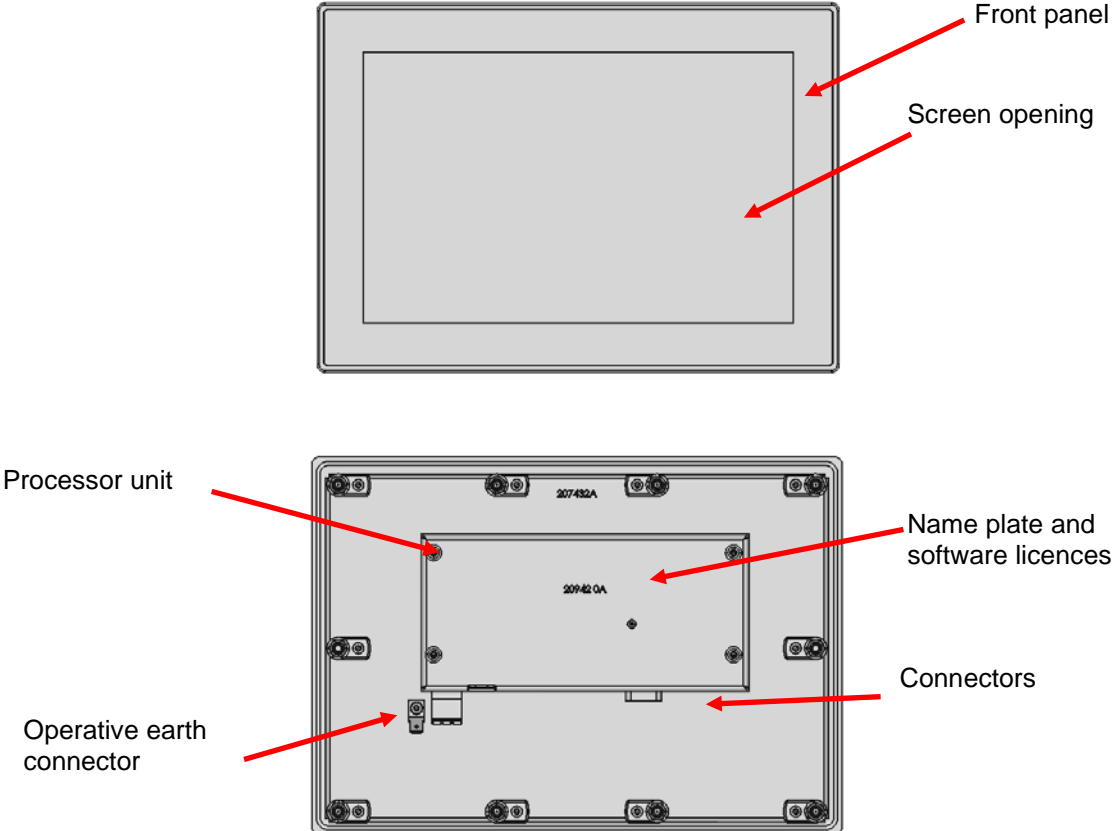

3.3 Labelling and Identification

3.3.1 Name Plate

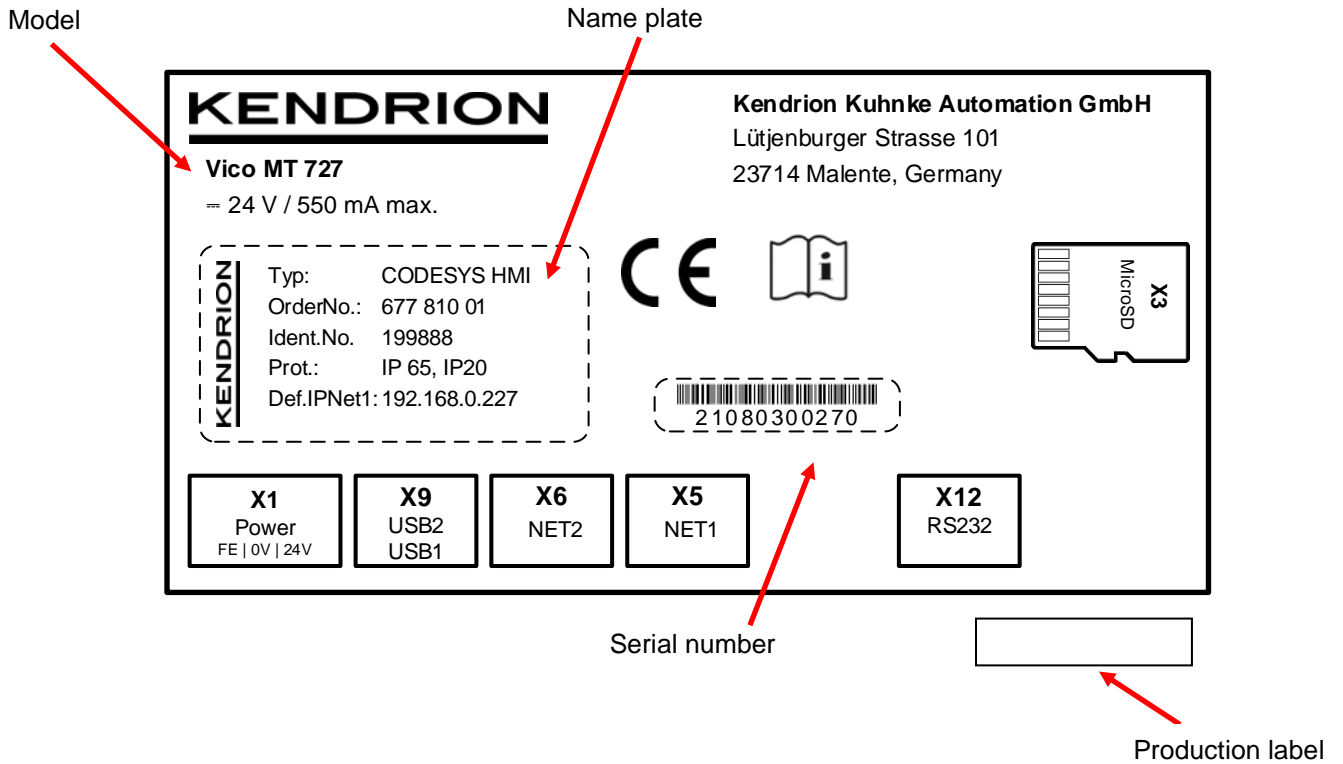

3.3.2 Name Plate Details

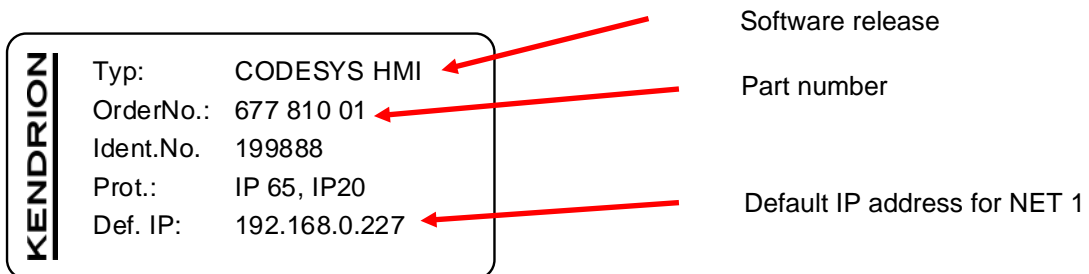

3.3.3 Serial Number

The numerical code incorporates the production date and a serial number. Kendrion Kuhnke can use the numerical code to distinctly identify the model, software and hardware release date. It is a means of traceability.

Make-up of serial number:

YY MM DD NNNNN

Example:

The unit shown above was manufactured on 03rd August 2021 and has the serial number 00270.

21 08 03 00270

five-digit number of nth unit built on that day

production date as year month day

3.4 Contents of Package

The Vico MT package includes:

Basic unit, supplement, power supply connector, mounting elements, which are already pre-assembled on the Vico MT 1027 and Vico MT 1527 devices.



3.5 Transport and Storage

Despite the unit's rugged construction, its components inside are still sensitive to impact and vibration. Transport and keep the unit in its original packaging and ensure that the ambient conditions are as specified at all times during transport and storage. Refer to manual section → 9.6.3 Admissible Ambient Conditions for admissible ambient and transport condition details.

	NOTE
	<p>Humidity <i>Damage to the unit</i></p> <p>⇒ Verify that no moisture (condensation) is able to collect on the unit when transporting it in cold temperatures or if it is exposed to extremely varying temperatures. Allow the unit to slowly warm up to room temperature before putting it into operation.</p>

3.6 Interfaces

All external connectors are located on the back of the unit. All connectors are of the plug-in type.

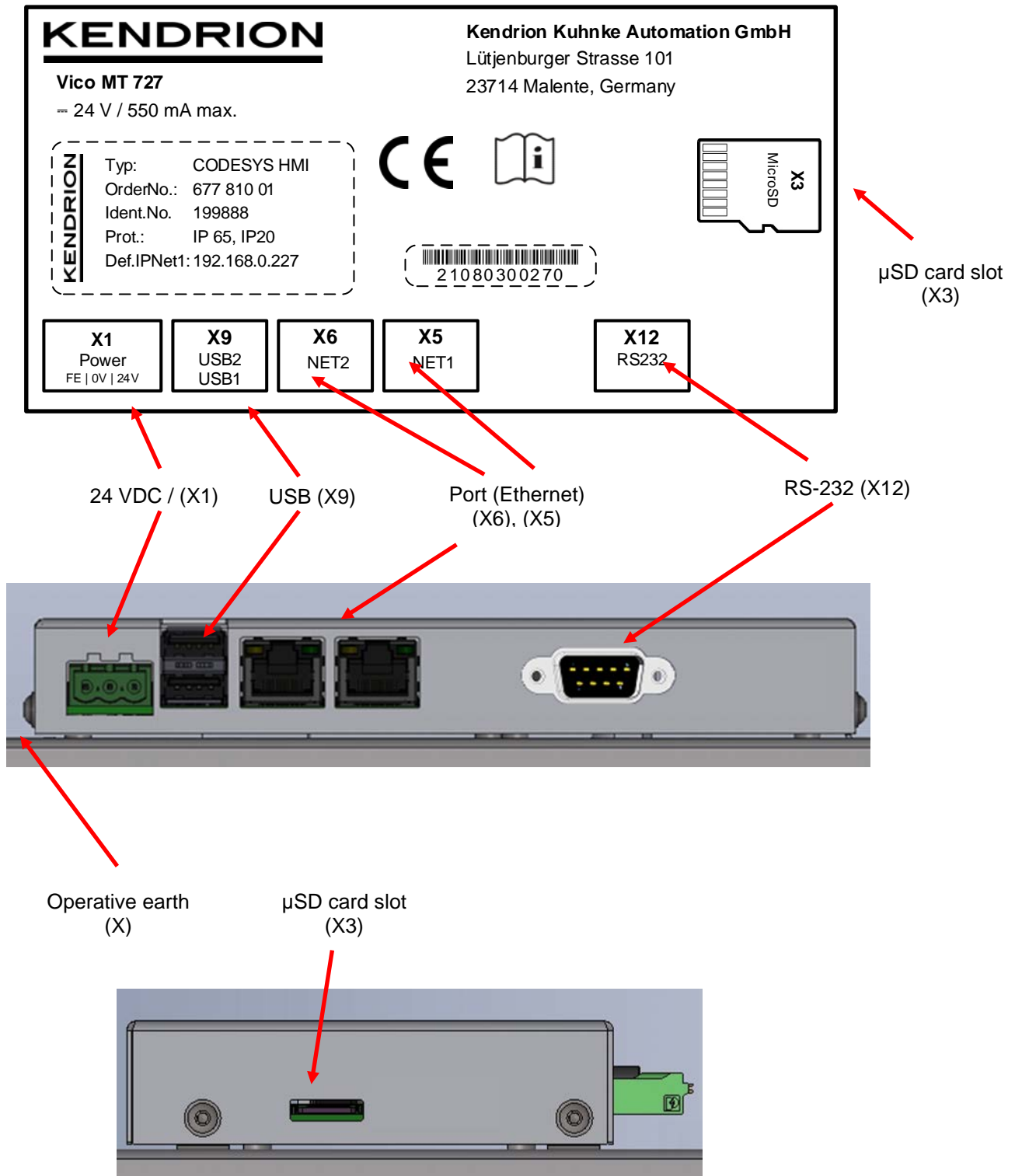

3.6.1 Power Supply "24VDC", (X1)

On-board power supply unit (PSU)

The device is designed for an input voltage of 24 VDC (+20% /- 20%). It is protected against reverse polarity. Both the cord to the device and the power supply unit must have external protection against short circuit and overload triggering at max. 10 A.

The unit's earth connector dissipates disturbances caused by external signal cables or cables of other assemblies. You should therefore use the operative earth connector of power supply connector X1 to provide a low-impedance earth connection. We recommend using 1.5 mm² diameter wires.

Pin wiring:

X9 24 VDC Power Supply		
Pin / Signal		Function
1	OE	operative earth
2	0 V	external 0 V power supply
3 /	24V	external power supply 24 VDC (18 V ... 32 V)

Connection data

X9 Mating Connector	
Type	screwed connection with spring bushing
Poles	2, single row
Order data	Phoenix FKCN 2.5/ 3-ST- 1732755 (included in package)
Wire cross section	flexible 0.2 mm ² ... 2.5 mm ² rigid 0.2 mm ² ... 1.5 mm ² AWG / kcmil: 24 ... 16
Stripped end:	10 mm

3.6.2 Operative Earth (X11)



Connect operative earth to the protective earth conductor of the switching cabinet or the system that the PC is installed in. Use the flat plug (6.3 mm x 0.8 mm) or the earth bolt at the back of the unit.

Verify that the cross section is not less than 1.5 mm². Try to keep the lead to the cabinet terminal as short as possible.



Information

A low-impedance earth conductor improves the dissipation of interference received via external power supply cables, signal cables or cables of peripheral units.

3.6.3 USB 2.0 host "USB1", "USB2" (X9)

The two USB host ports are made for attaching USB peripherals. They provide a max. current of 0.5 A each.

Pin wiring:

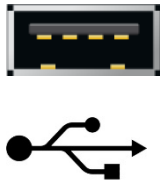

X4 / X5		USB	
Connector	Pin	Function	
USB	B1	VCC	
	B2	D-	
	B3	D+	
	B4	GND	



NOTE

USB port overload by excessive power consumption

Machine failure and/or data loss

- ⇒ Only attach USB peripherals whose total power needs do not exceed 0.5 A or supply external power to the USB peripherals by adding an active hub to the line, for example.



NOTE

Electromagnetic interference in industrial environments

Machine failure and/or data loss

- ⇒ Mind that the USB interface is not designed for use in industrial environments but just as a service interface for loading software updates or data up into or down from the control unit.

USB sticks

USB stick users should consider the following points:

The USB port is mechanically designed to support up to 1,000 plug/unplug operations.

Pulling off a USB stick during operation is allowed only when no more file operations are being performed.

Failure to comply may render the USB stick useless!

If a program still has a file open when the USB stick is pulled, you will find it impossible to close the directory that the file belongs to. In this situation, the system will not respond to any file or directory operation requests because it would be expected to read from a device that is no longer available. Therefore, before pulling off the USB stick, you should always ensure that no program still has an open file loaded from the stick.

3.6.4 Ethernet "NET1" (X5)

The on-board 1000 Mbit base-T Ethernet adapter attaches the unit to a gigabit Ethernet network through its RJ-45 connector.

It automatically detects and adapts the interface to 10BaseT or 100BaseT Ethernet networks.

The LEDs labelled "LNK" and "RCV" tell you whether the unit is properly connected to the network.

Cable: shorter than 30 m, shielded, min. Cat-5e

Pin wiring:



NET1
X5

X5		NET1	
Connector	Pin	Function	
 RJ45	S	Shield	Shield
	1	D1+	TX+
	2	D1-	TX-
	3	D2+	RX+
	4	D3+	
	5	D3-	
	6	D2-	RX-
	8	D4-	
LED "LNK"	green / orange	data link	
LED "RCV"	orange	activity	

3.6.5 Ethernet "NET2" (X6)

The on-board 10/100 Mbit base-T Ethernet adapter attaches the unit to a network through its RJ-45 connector. The LEDs labelled "LNK" and "RCV" tell you whether the unit is properly connected to the network.

Cable: shorter than 3 m, shielded, min. Cat-5e

Pin wiring:



NET2
X6

X6		NET2	
Connector	Pin	Function	
 RJ45	1	TX+	
	2	TX-	
	3	RX+	
	4	75 Ohm	
	5	75 Ohm	
	6	RX-	
	7	75 Ohm	
	8	75 Ohm	
LED "LNK"	green / orange	data link	
LED "RCV"	orange	activity	



NOTE

Unauthorised access to the computer

Controller failure and data loss

- ⇒ Integration in networks granting public access requires the user to take appropriate measures aimed at preventing unauthorised access.

3.6.6 Serial Communication RS-232 "X12"

The serial COM1 port provides signals RxD, TxD, CTS and RTS at an RS232 signal level. It is not electrically isolated.

Pin wiring

Cable: shorter than 3 m, shielded

X7 RS 232 interface			
Connector	Pin	Function	
	1	-	
	2	RxD	RS232 Receive Data
	3	TxD	RS232 Transmit Data
	4	-	
	5	GND	
	6	-	
	7	RTS	RS232 Request to Send
	8	CTS	RS232 Clear to Send
	9	-	
	Case	GND	

Technical data

RS 232	
Quantity	1
Signal	RS 232
Baud rate	max. 250 kbps
Electrical insulation	no galvanic isolation

3.6.7 MicroSD Card (X3)

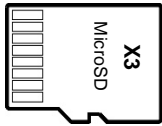

The unit features a MicroSD card slot located on the right side. A MicroSD icon marks the slot.

SD, SDHC and SDXC cards at capacities of up to 2 Tb are supported.

Insert the MicroSD card with the contacts pointing to the back (to the rear of the unit).

The MicroSD card slot has a push-in/push-out plug & eject mechanism. You may have to use a flat object to help you plug in or eject the card.

Industrial vs. commercial products

To operate the unit in industrial environments, you should preferably use industry-grade SD cards instead of commercial ones.

Features of industry-grade SD cards:

- SLC or iMLC memory
- Secure write and clear cycles
- Longer period of availability and early discontinuation announcement

	NOTE
	<p><i>SD card data can neither be read nor written</i> <i>Control unit / machine failure</i></p> <p>⇒ To operate the unit in industrial environments, you should preferably use industry-grade SD cards instead of commercial ones. Using other than the above SD cards may jeopardise operational safety.</p>

	NOTE
	<p><i>Electrostatic discharge (ESD)</i> <i>Inappropriate handling will destroy the memory card</i></p> <p>⇒ SD/MicroSD cards are susceptible to electrostatic discharge (ESD). Please take account of the instructions on how to handle memory cards.</p>

3.7 Indicators and Controls

3.7.1 Ethernet "NET1" (X5), "NET2" (X6)

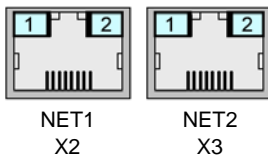

LED Both LAN1 and LAN2		
Designation	LED	Explanation
1	off	no activity, no link
	flashing green	activity, link
2	off	no link 1000
	yellow	link 1000

3.8 Front

The chemically strengthened and toughened glass resides in a milled aluminium frame without edges. We recommend using a soft cloth and customary household glass surface cleaner to clean the panel front. See → 6.7.3 Preventive Maintenance for further details.

3.8.1 Screen

The IPS displays installed reliably reproduce colours and provide a wide aspect angle.

3.8.2 Backlight

Use the system setup utility or a Linux command to set the backlight brightness.

3.8.3 Touch

The touch sensor of projective capacitive (PCAP) or PCT touch screens is located under the glass, which turns this device into a particularly rugged and versatile piece of technology.

It is fully integrated and connects to the CPU board via an internal interface. The front glass is chemically strengthened/toughened. The analysis circuitry is able to detect up to 5 fingers.

	CAUTION
	<p><i>Hitting the screen glass with a hard object may damage the glass and cause injuries later. Use your finger or stylus to operate the screen.</i></p>

4 Installation and Operation

	WARNING
	<p>Consider the standards and regulations applicable in the country of use <i>Improper installation may cause death and serious personal or property damage.</i></p> <p><i>Consider all standards and regulations applicable in the country of use and only have trained experts knowing all the formalities install the unit in machines or systems.</i></p>

	Information
	<p><i>Before installing, servicing or putting the unit into operation, please also read the safety information in the preface of this document.</i></p>

4.1 Mechanical Installation

Vico MT is a modern electronic assembly. Handle – specifically mount, operate and service – with care.

Whereas touch screens are generally very tough, you should still take account of a couple of basic facts when installing them.

Check that the front of the housing is always flat and that the material is not warped, irrespective of which material is used. Do not expose the front panel to any mechanical pressure (bending stress).

4.1.1 Mounting Position

By design, the unit may be installed vertically only. Not installing it according to instructions may prevent heat dissipation and therefore cause it to overheat, which may then provoke a loss in performance or cause the unit to switch off unexpectedly.

Take particular care not to place the unit on a table top or the floor to operate it.

	CAUTION
	<p><i>Risk of overheating and fire!</i></p> <p><i>Even if operated at admissible ambient temperature, the unit may be destroyed if the way of installation stops the convection cooling from working.</i></p> <p>⇒ Please take heed of the notes on the mounting position.</p>

Leave some free space above, beneath, at the sides and back of the unit to allow enough air to circulate. Be sure to leave at least 50 mm of free space on all sides. This specification applies to all variants.

4.1.2 Front Panel Opening

- Cut an opening into the control panel area where you wish to install the unit. Refer to the appropriate drawing or table to find the correct panel dimensions.

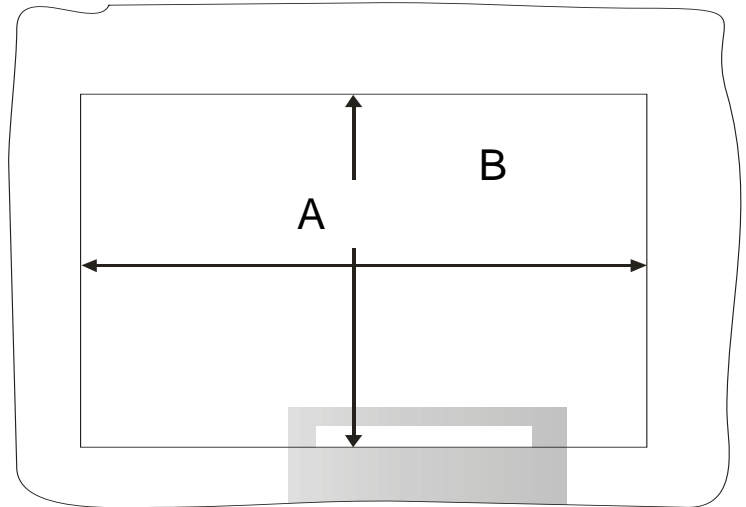



Front Panel Opening		
Model	Width A	Height B
Vico MT 727	189.7 mm	121.5 mm
Vico MT 1027	252 mm	174.5 mm
Vico MT 1527	395.5 mm	244.5 mm

* Please note the drawing

7" display panels

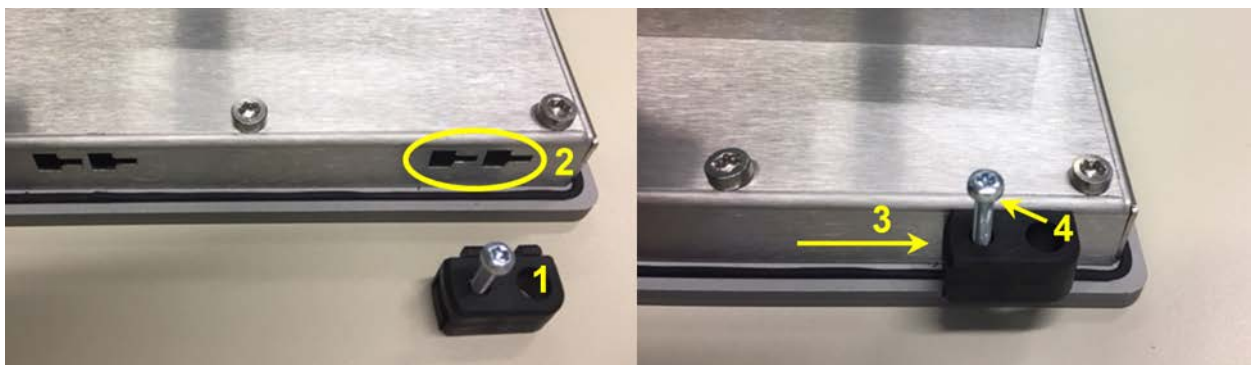
- Approaching the switching cabinet from the front, slide the unit into the opening and gently push it all the way in until it contacts the cabinet front.
- At the back: Place the mounting hardware (1) in the T slots on the side (2) and laterally slide them in (3) until the snap into place.
- Go to the first piece of mounting hardware in a corner and tighten the screw (4) until it pushes against the cabinet panel. Tighten the screws to max. 0.2 Nm.
- Repeat at the mounting element opposite and across.
- Repeat the crosswise procedure on the remaining elements.



	NOTE
	<p><i>Damage to the mounting elements</i> <i>Take heed of the maximum tightening torque to avoid damaging the screws of the mounting hardware.</i></p> <p>⇒ Tighten the screws of the mounting hardware to max. 0.2 Nm.</p>

	NOTE
	<p><i>Twisting of unit or ingress of moisture</i> <i>Incipient or complete touch screen damage or leakiness</i></p> <p>⇒ Verify that the material around the installation opening is hard enough to ensure that the panel control unit is mounted correctly at all times. In order to achieve the specified ingress protection, the material must not warp under the load of the mounting bolts or operation.</p>

10.1" or larger display panels

- Approaching the switching cabinet from the front, slide the unit into the opening and gently push it all the way in until it contacts the cabinet front.
- Swivel out the mounting elements at the back until their screws are above the cabinet panel.
- Go to a piece of mounting hardware in a corner and tighten the screw until it pushes against the cabinet panel.
- Repeat at the mounting element opposite and across.
- Repeat the crosswise procedure on the remaining elements.



4.2 Electrical Installation

The connectors are located on the back of Vico MT or as described in section → 3.6 Interfaces.

Proceed in the order below to wire up the unit:

- turn off the unit,
- unplug the unit from the mains/power supply,
- attach all cables to the unit and any peripherals,
- check that all cables are firmly attached at both (female and male) ends,
- reconnect all units with the mains/power supply.

4.2.1 Operative Earth

Operative earth is not a safeguard but a means of improving the immunity to noise. It is solely intended to dissipate noise current but not to protect persons from contact.

It connects to one of the 6.3 mm x 0.8 mm blade connectors at the back of the unit or using connector X1.

Take heed of the following points to ensure that noise currents are safely dissipated:

- Try to keep a very short distance between the unit and the central earth bonding point on the control cabinet.
- Check that the cable/earth conductor diameter is 1.5 mm² or greater.

Take heed of the specified conductor shielding; check that all data link cables attached to the unit have shielded wires and attach to the unit's earthing terminals.

	WARNING
	<p><i>Malfunction due to improper earthing of the unit.</i></p> <p><i>The unit will stay within the specified EMC limits if it has been earthed properly.</i></p> <p><i>Appropriately connect the unit to earth.</i></p>

4.2.2 System Power Supply

Power is supplied via the 0 V and 24 V terminals of connector X1. The wires should have a cross section of 0.25 mm² to 2.5 mm² and a connector sleeve. Attach the connector sleeves to the wires, then insert the wires in the terminal chamber and tighten the screw terminals using a suitable screwdriver.

Check the pin wiring specified for the unit's power supply connector when wiring up the unit.

	CAUTION
	<p><i>Damage to the unit due to supplying excessive or the wrong power</i></p> <p><i>Wrong voltage or wrong polarity of the connectors may destroy the unit.</i></p>

	CAUTION
	<p><i>Check that the power supply cable will sustain a minimum operating temperature of 75 °C.</i></p> <p><i>If the specified temperature of the cable is insufficient, the cable may become brittle or start emitting potentially harmful substances over time.</i></p>

	WARNING
	<p><i>Check that the PSU output complies with the safe extra low voltage (SELV) criteria of IEC 60664-1.</i></p> <p><i>Using a non-compliant PSU may provoke an electric shock hazard.</i></p>

Power supply ratings

Supply voltage: +24 VDC \pm 20 %

Current consumption: 0.15 A – 1 A

Power consumption: 3.6 W – 24 W



Internal fusing: 2 A fuse

Overvoltage category II, max. 300 V, on the primary side

Recommended PSU rating: Voltage/output power: 24 VDC / min. 30 W

Power supply fusing

The cord must have external protection against short circuit and overload triggering at max. 10 A, min. 60 V.

	NOTE
	<i>Damage to connectors or cables by improper plugging or unplugging</i> <i>Improper (un-)plugging may damage the cables, connectors and other parts of the system.</i> ⇒ Always hold the lead by the connector to plug or unplug it.
	Information
	<i>Actual power consumption depends on the display size, the brightness and the type and number of active interfaces.</i>

4.3 Putting into Service

4.3.1 General Start-up Information

	CAUTION
	<p>Risk of burns</p> <p><i>The surface of the device may become very hot. Unprotected contact causes a risk of burning yourself.</i></p> <p>⇒ Avoid direct contact with the unit in operation. Put on suitable safety gloves before touching the unit.</p>

	NOTE
	<p>Pull of the protective film to the side</p> <p>⇒ <i>The protective film on the front removes easily by pulling it off to the side.</i></p>

Touch screen operation

Operate the touch screen objects by touching them with your finger or a suitable stylus.

	NOTE
	<p>Damage to the touch screen by pointed or hard objects</p> <p>Destruction of front</p> <p><i>Do not use pointed or hard objects to operate the touch screen.</i></p> <p>⇒ Avoid sudden or impact-like touch screen contact by hard objects because this may destroy the touch screen. Touch the screen of Touch with your finger or the stylus only.</p>

4.3.2 Start-up Prerequisites

- Functional earth is connected.
- All cables are attached properly.
- Power is supplied to the unit.

4.3.3 Turning on the Unit

Connect the unit to the power supply.

The unit does not have an On/Off switch. Instead, it will start up automatically when you turn on the power supply. The user interface of the operating system displays after the boot-up routine.

4.3.4 Turning off the Unit

You may directly unplug the unit from the power supply.

4.4 IT Security

Automation devices contain functional units that should be protected. These include the conventional control and regulation functions and algorithms but also the facility users' production and other data. Since there is no automation solution without faults, some potential weak points and causes of risks remain. Whereas the main threat is from LAN networks, attackers may also use local interfaces.

Consider the following routes of attack:

- Interfaces (USB, LAN, WLAN, Bluetooth,.....)
- Services, drivers, protocols (RPC, HTTP(S),.....)
- Authentication, encoding (compulsory registration, encrypted password)
- Physical access (closed rooms, cabinets)
- Third-party systems or personnel

Take every effort to avoid exposing the PLC and controller networks to open networks or the Internet. Safeguarding should include extra data link layers such as remote access via VPN as well as sophisticated firewalls. As a basic rule, you should disable or restrict the access to all interfaces you do not need. Segmentation (e.g. by a router with a firewall) may be another effective means of protection.



NOTE

Unauthorised access to the computer

Controller failure and data loss

- ⇒ Integration in networks granting public access requires the user to take appropriate measures aimed at preventing unauthorised access.

4.5 Configuration

Use a web interface or the on-board utility to configure the units of this series. You can choose to start the configuration utility either directly by picking the appropriate option as the unit starts up or by running an Internet browser on an external device and configuring the unit via its Ethernet connection.

Refer to chapter 7 System Configuration for the available access and setup options.

The screenshot shows the SYSTEMCONFIG web interface. At the top, it displays network status for NET1 and NET2 (both 192.168.0.227/255.255.255.0), the date and time (Thu Oct 21 05:01:59 UTC 2021), and system uptime (0:03:09:40). The interface is titled 'SYSTEMCONFIG (remote access)' and features the KENDRION logo. A left sidebar lists various system settings, with 'Network' highlighted in red. The main content area is titled 'Ethernet' and includes fields for Hostname (11555), Default Gateway (192.168.0.1), and a dropdown for 'Using Device' (eth0). Below this is a 'LAN' section with 'Add' and 'State' buttons. Two network interfaces are listed: 'eth0' and 'eth1'. The 'eth0' interface has a 'Check Internet Connection' button, a 'DHCP Enabled' toggle (currently off), and fields for Address (192.168.0.227) and Netmask (255.255.255.0). The 'eth1' interface also has a 'Check Internet Connection' button. A 'Reboot' button is located at the bottom left of the interface.

4.6 Diagnosis

4.7 Table of Faults

Table of Faults		
Fault	Possible Cause	Recommended Action
No function	Power not or incorrectly supplied to the unit	Check that X1 is wired correctly. Measure the voltage supplied.
Date and time are not stored permanently	The time is lost after a power failure.	Periodically synchronise using the Network Time Protocol (NTP)
Touch screen No function Overreacts	The unit is not earthed properly and electric fields provoke wrong entries to the PCAP touch	Earthing via terminal X1 or a flat contact. Users should earth before operating the touch screen.
Interface function compromised	Interface cable not plugged properly	Check that all interface cables are plugged properly.

4.8 Maintenance / Servicing

4.8.1 General

Only qualified persons are allowed to work on the unit.

	CAUTION
	<p><i>Do not plug, mount, unplug or touch the connectors during operation!</i> <i>Destruction or malfunction</i></p> <p>⇒ Turn off all power sources before working on the unit. This also applies to any peripherals connected such as encoders, programming devices with external power source, etc.</p>

4.8.2 Servicing

The unit requires neither servicing nor any action if it is kept and operated at the admissible ambient conditions specified in section Technical Data.

4.8.3 Preventive Maintenance

Cleaning the front panel

To prevent other persons from unintentionally operating the unit, be sure to turn it off before you clean its front panel.

	CAUTION
	<p><i>Unintentional start of functions</i> <i>Movements of machine parts</i></p> <p>⇒ In order to avoid unintentionally starting a function by touching the screen or pressing controls when cleaning the unit, verify that the unit is properly turned off.</p>

Use a damp cloth to clean the unit. To moisten the cloth, only use water with washing liquid, screen cleaner or alcohol (ethanol) in it. Do not spray the cleaning agent straight on the unit but always on the cloth first. Do not use aggressive solvents, chemicals, scouring agents, compressed air or steam jets.

To avoid damaging the front panel by cleaning, please take heed of the following:

- Do not use pressure washers or steam jet ejectors.
- Do not use corrosive cleaning agents, diluted acids, scouring cleaners or hard objects for cleaning.
- Do not put too much pressure on the front when cleaning it.

Prevent inadmissible contamination while operating and storing the unit.

4.9 Life Expectancy

4.9.1 Repairs / Customer Service

	Information
<i>Only the manufacturer or customer service providers authorised by the manufacturer are allowed to do repairs and perform corrective maintenance.</i>	

4.9.2 Warranty

The statutory period and conditions of warranty apply. Warranty expires if unauthorised attempts are made to repair the unit / product or any other intervention is performed.

4.9.3 Taking out of Service / Disposal

Disposal requires the device to be disassembled and entirely taken apart. All metal components can be given to metal recycling.

Electrical and electronic waste and batteries

Dispose of electrical and electronic waste and batteries pursuant to local regulations. Contact your local disposal services provider for further details. Do not dispose of the units as domestic waste or via incineration.

Remove the back-up battery, if any, and dispose of it separately.

5 System Configuration

The on-board web interface provides many user-friendly configuration options as well as sophisticated software add-ons for the specific needs of industry users.

The sections below are brief descriptions of the configuration options.

The menus, their items and the available settings depend on which model you are using, the software packages installed (e.g. type of web browsers, CODESYS HMI) and your operating system. They may therefore differ from the ones described in this manual.

5.1 Accessing the System Configuration

The Web Interface ensures ease of configuration. You can choose to start the configuration utility either directly by picking the appropriate option as the unit starts up or by running an Internet browser on an external device and configuring the unit via its Ethernet connection.

The menus are arranged well to help you quickly find a particular setting such as the network settings, URL, display, FTP, IP tables, screen saver, web browser and CODESYS settings, passwords, diagnosis etc.

Standard IP addresses for panel access (factory defaults):

NET1: 192.168.0.227 (subnet: 255.255.255.0)

NET2: 192.168.1.227 (subnet: 255.255.255.0)

Standard passwords (factory defaults):

User: root

Password: root

5.2 Functions and Settings

5.2.1 Header

The header summarises all key details.



Left side:

- Network addresses of Ethernet 1 (NET1), Ethernet 2 (NET2), WLAN and VPN. Active network connections are marked by a blue icon to the left.

Centre:

- Current system time
- Uptime
- Image version of your firmware.

5.2.2 Network

You can choose to assign a dynamic (DHCP) or static (fixed IP) network address. The address is a unique identifier of your unit within the network. The correct settings depend on the network you are running your unit in. The Web Configurator's Network page also lets you change the WLAN settings.

5.2.3 Display

Use the Display page to set the logos to appear at startup, the display brightness and the touch front calibration.

5.2.4 Time Date

Since Vico MT-series devices do not buffer the time, you will have to reload the time from the Internet every time you start the unit.

Pick the Time Date menu item to set the time zone and NTP script to be used for periodically loading the time signal.

	Information
	<p><i>Project pool.ntp.org is a large virtual cluster of time servers providing a reliable and simple means of synchronising the times of millions of computers connected to the Internet via NTP. Several millions of system worldwide use this pool, which is the "default time server" of most of the Linux-based operating systems and some network devices.</i></p>

5.2.5 Disks

The Disk settings define how the connected drives (such as thumb drives) will behave.

5.2.6 Fonts

The Fonts category lists all fonts currently installed on your system.

You can use it to install more fonts.

5.2.7 Access SystemConfig

Use this page to define or change the access and system settings of your system configuration. Tap on Apply to save and directly apply the settings without having to restart your system or tap on Reload to reload them.

5.2.8 Access FTP Server

Run your unit's FTP server to upload or download any file(s) (such as fonts) from or to your unit.

5.2.9 Firewall (iptables)

This page displays the firewall settings.

5.2.10 OpenVPN

This page displays the OpenVPN settings.

5.2.11 System Info & Access

This page tells you which system version is installed. It also allows you to configure the access to the Linux operating system.

5.2.12 Resources Monitor

This page displays the current states of your hardware resources.

5.2.13 Process List

This page displays details of all running processes.

5.2.14 Log

This page displays up-to-date log details.

5.2.15 Log Persistent

Choose this menu item to set up "persistent logging" on a data medium.

5.2.16 Terminal

This menu item provides a simple terminal utility. It does not support commands needed for permanent communication (e.g. nano, ps, etc.). A command is cancelled if it is not returned within 10 seconds.

Security Manager

This menu item lets you check/display the security functions of the active system.

5.2.17 Boot Script

This menu item controls a shell script that, if enabled, the operating system will run automatically when you boot the unit. Run the Script Editor to create/edit the shell script.

5.2.18 Backup/Restore

Use this menu item to back up or restore the settings of the system and the application or the entire system. This function (live system) provides you with a simple means of backing up or restoring the entire unit to or from a thumb drive or SD card. A system backup allows you to restore the units to a defined state or to clone them.

5.2.19 System Backup/Restore (Live System)

This function (live system) is an easy means of backing up or restoring the entire unit to or from a thumb drive or SD card.

A system backup allows you to restore the units to a defined state or to multiply them.

5.2.20 Browser Settings

This menu item lets you configure various properties of the on-board HTML5 Chromium browser, e.g. its URL at startup, its appearance and behaviour, or the keyboard and language settings.

5.2.21 Browser Log

Pick this menu item to display the browser log.

5.3 System Functions

5.3.1 Keyboard

The configuration includes support of American USB keyboard layouts without further ado.

5.3.2 Mouse Support

USB mice are supported by default. As soon as a USB mouse has been detected, the mouse pointer will appear on the screen and disappear again when the USB mouse is removed.

5.3.3 Run Linux Scripts Automatically

Options are to automatically run Linux scripts from a thumb drive either at startup or while the unit is running. Use this function to install further files, fonts or Linux packages or to change any of the system settings.

To do so, create an "init" directory on a thumb drive and save your scripts there. All scripts in the directory will run automatically. Check that the extension of all script files is ".sh" or that they have been stored in the UNIX format.

5.3.4 Configuring the Web Browser

All web browser settings are stored in file "/opt/qtwebbrowser/settings.ini" on your unit.

Ask for a free configuration sample.

5.3.5 Installing Fonts

Fonts are saved to directory "/usr/lib/fonts/ttf/" on your unit.

Ask for a free configuration sample.

5.3.6 Configuring the Network

The network settings are stored in file "/etc/network/interfaces" on your unit.

Ask for a free configuration sample.

6 Appendix

6.1 Software Copyrights

The unit's software contains product components of third-party software makers. This section summarises the copyright details regarding the software resources concerned.

CODESYS Control runtime system

Equipment manufacturers installing the CODESYS runtime system on their devices are sent a licence file when they purchase the [CODESYS Control Runtime Toolkit](#). Licence fees have to be paid for every CODESYS-programmable device ("Runtime Royalties"). To show that a device is licensed, the equipment manufacturer is given a certificate for the toolkit and any optional add-ons.

6.2 Drawings

6.2.1 Dimensions of Vico MT 727

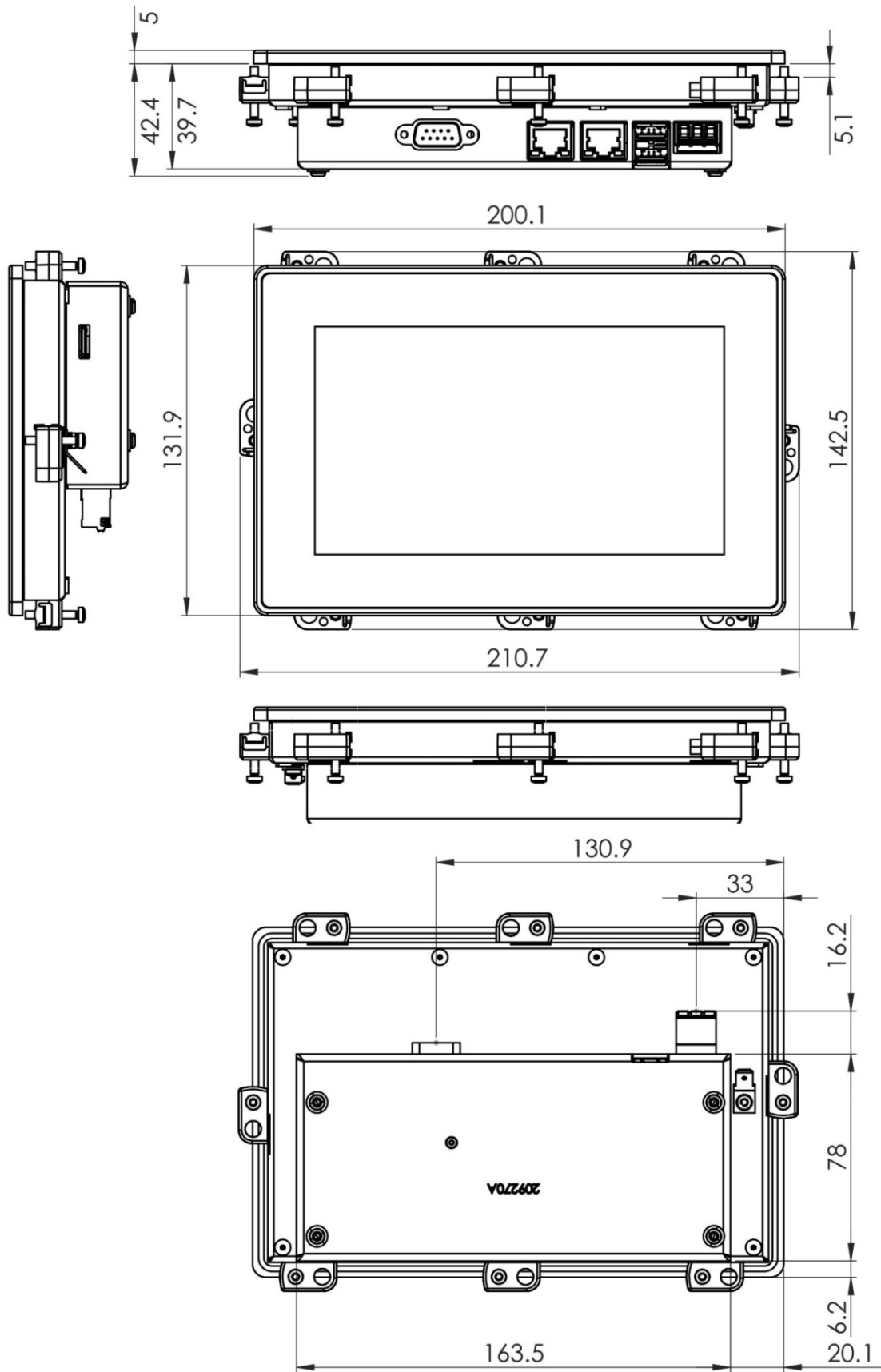

6.2.2 Installation Opening of Vico MT 727

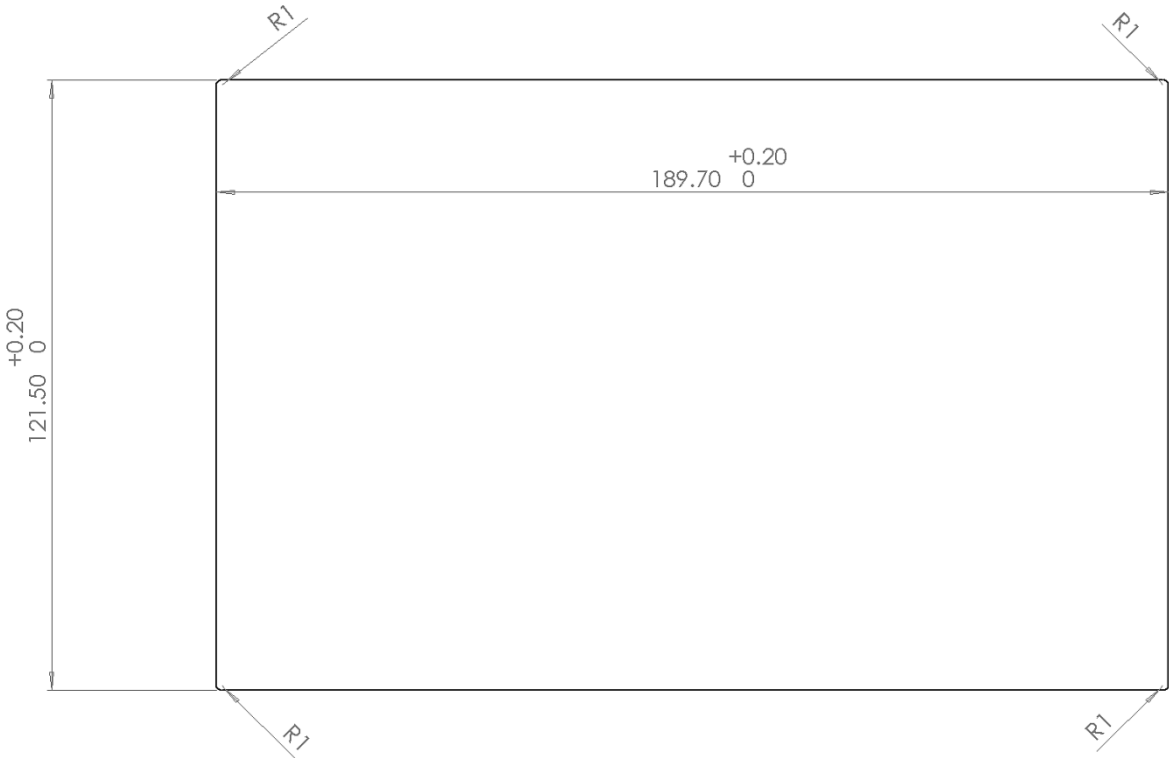

6.2.3 Front View of Vico MT 727

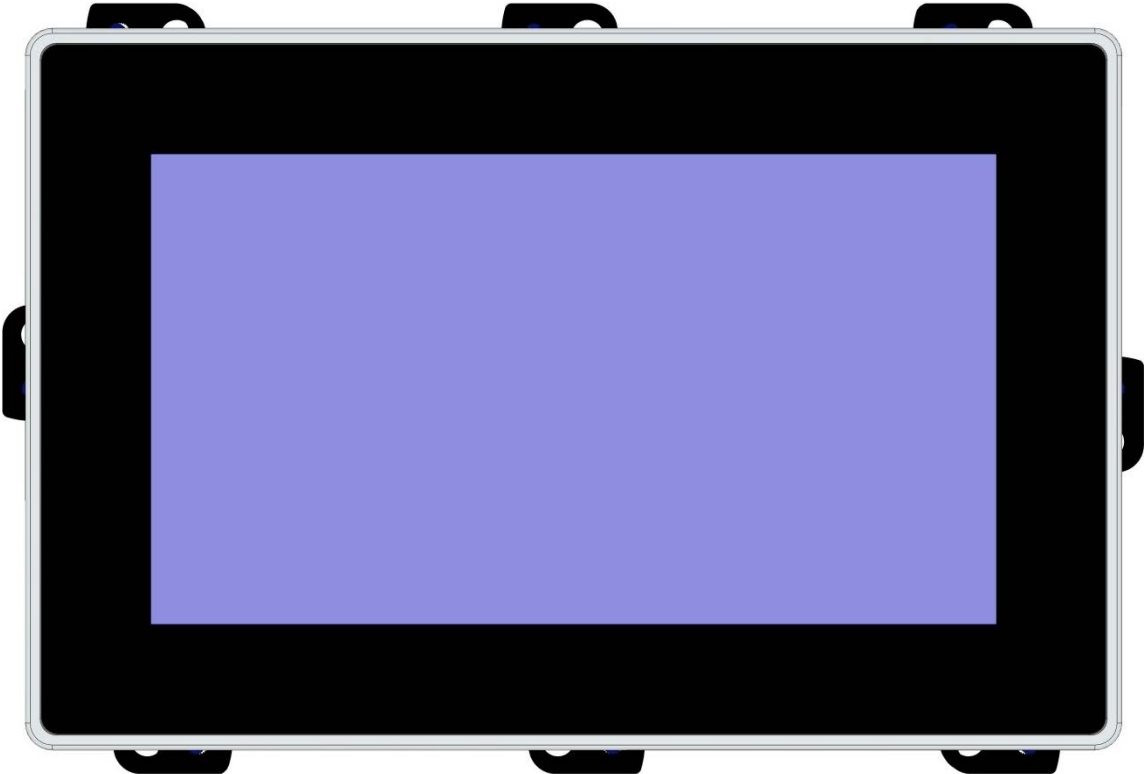

6.2.4 Dimensions of Vico MT 1027

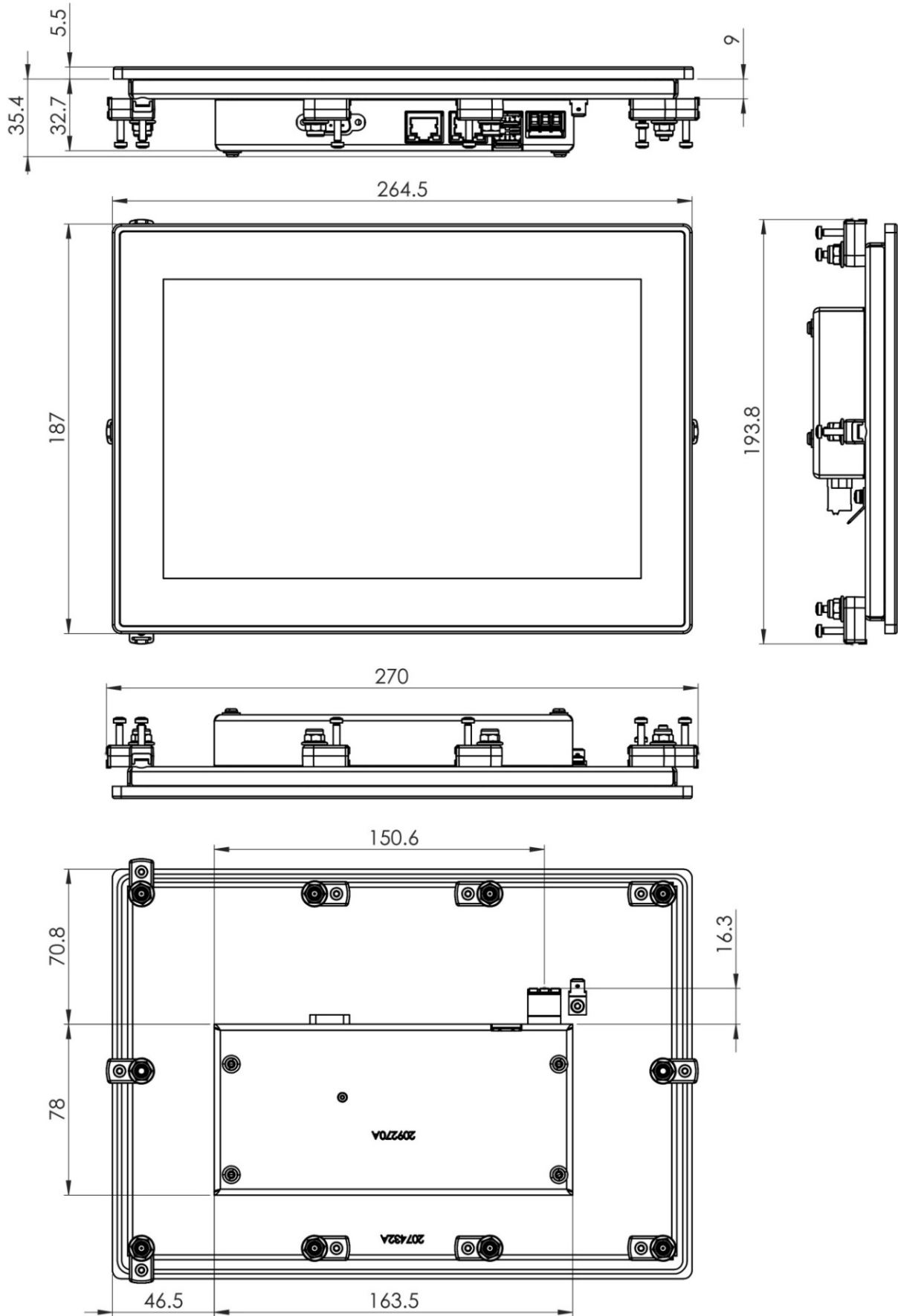

6.2.5 Installation Opening of Vico MT 1027

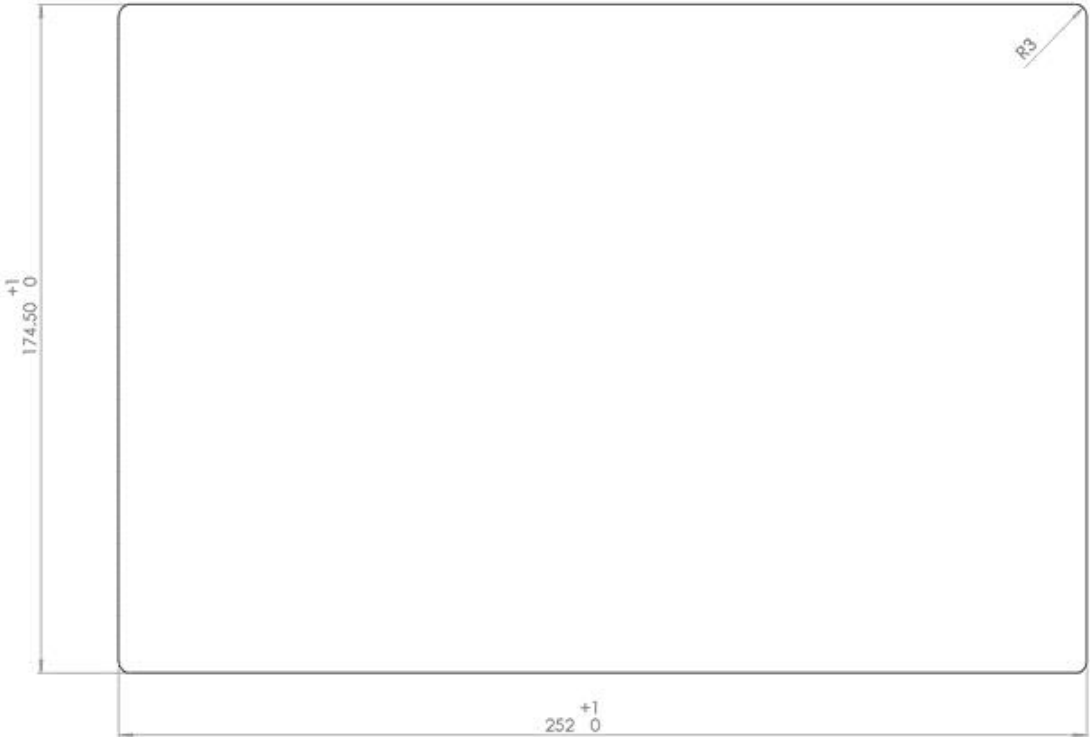

6.2.6 Front View of Vico MT 1027



6.2.7 Vico MT1527

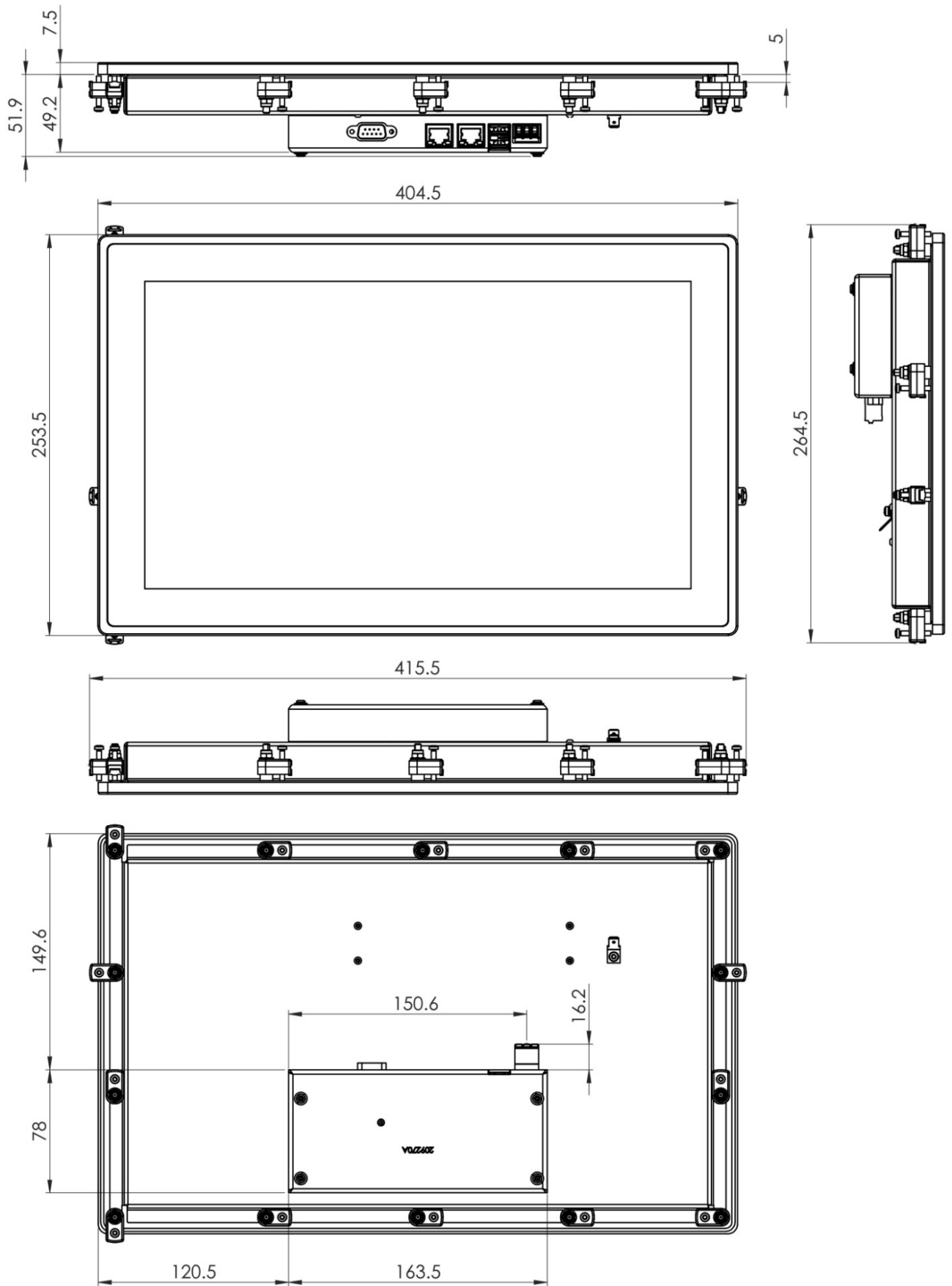

6.2.8 Installation Opening of Vico MT1527

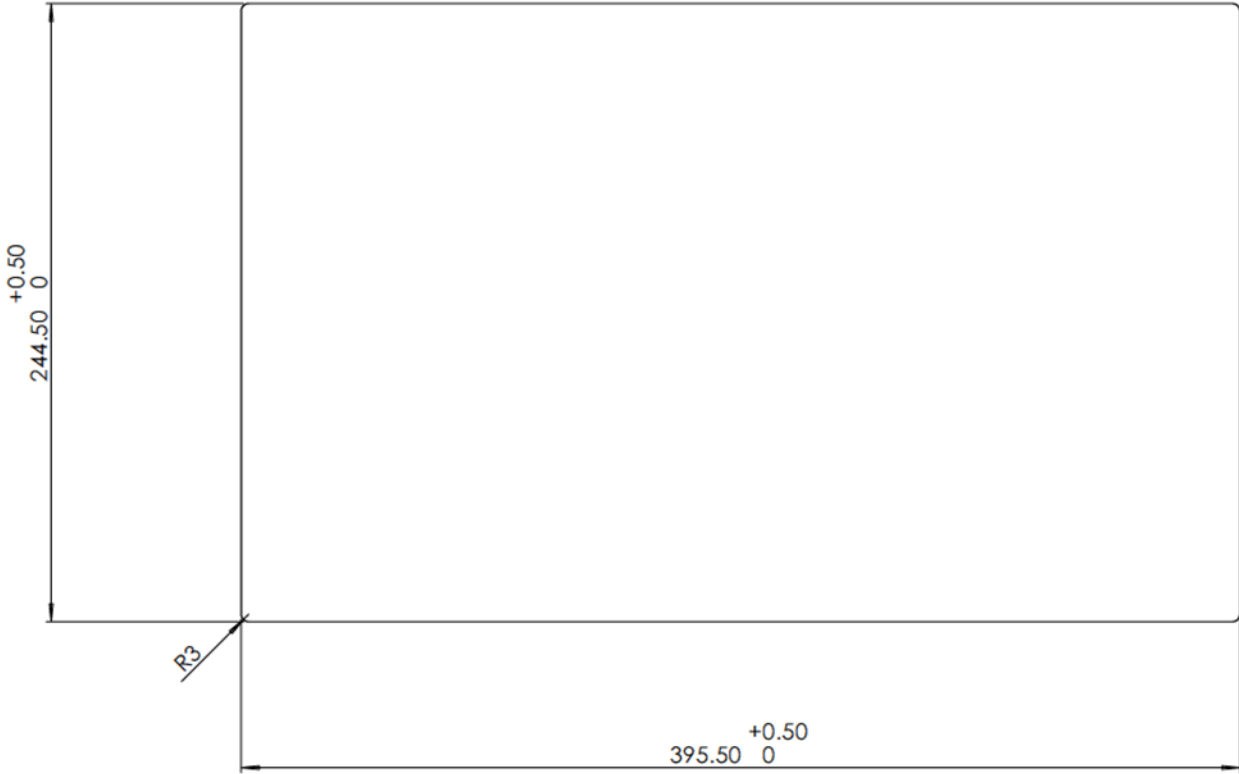

6.2.9 Front View of Vico MT1527



6.3 Applicable Standards and Limits

6.3.1 EMC Standards

- EMC noise emission pursuant to IEC 61000-6-4 (industrial environments)
- EMC noise immunity pursuant to IEC 61000-6-2 (industrial environments)

6.3.2 Admissible Ambient Conditions

Storage and transport

Temperature -20...+70 °C

Relative humidity 10% to 95% at 25°C (no condensation)

Operation

Place of use industrial environment

indoor use only, front of unit supports wet environment, degree of contamination 2 pursuant to IEC 61010-1

Atmosphere: free from corrosive or explosive gases

Altitude max. 3000 m

Ambient temperature vertical installation: 0...55 °C

Relative humidity 10% to 95% at 25°C (no condensation)

6.4 Regulations and Declarations

6.4.1 Mark of Conformity

The EC-Declarations of Conformity and the associated documentation can be made available to the competent authorities pursuant to the above EU Directive. Please contact the Project Management, as necessary.



6.5 Approvals

The series of units has been granted the following approvals:

RoHS ✓

Conforms to RoHS Directive 2011/65/EU and Directive 2015/863/EU derived from it limiting the use of certain hazardous substances in electrical and electronic equipment

Applicable exceptions pursuant to EU Directive 2011/65/EU Annex III, 6 a – c

6.6 Order Specifications

6.6.1 Basic Units

Technical Data

Vico MT 727 HMI

677 810 00

CODESYS HMI terminal with multi-touch screen
 7-inch TFT display, wide format (1024x600), typ. 450 cd/m²
 Capacitive multi-touch screen, glass 1.8 mm thick
 Glass front resides in milled aluminium frame (with end caps)
 Processor ARM Cortex A53, i.MX8Mmini quad-core CPU, 4x 1.6 GHz
 Housing: aluminium at front (IP65), stainless steel at back (IP20)
 Power supply 24 VDC ± 20%



Vico MT 1027 HMI

677 810 10

CODESYS HMI terminal with multi-touch screen
 10.1-inch TFT display, wide format (1280x800), typ. 420 cd/m²
 Capacitive multi-touch screen, glass 1.1 mm thick
 Glass front resides in milled aluminium frame (with end caps)
 Processor ARM Cortex A53, i.MX8Mmini quad-core CPU, 4x 1.6 GHz
 Housing: aluminium at front (IP65), stainless steel at back (IP20)
 Power supply 24 VDC ± 20%

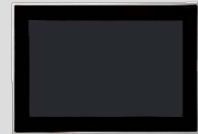

Vico MT 1527 HMI

677 810 30

CODESYS HMI terminal with multi-touch screen
 15.6-inch TFT display, wide format (1366x768), typ. 350 cd/m²
 Capacitive multi-touch screen, glass 1.8 mm thick
 Glass front resides in milled aluminium frame (with end caps)
 Processor ARM Cortex A53, i.MX8Mmini quad-core CPU, 4x 1.6 GHz
 Housing: aluminium at front (IP65), stainless steel at back (IP20)
 Power supply 24 VDC ± 20%

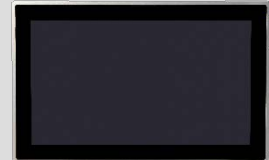

Vico MT 727 WEB

677 810 01

Web terminal with multi-touch screen
 7-inch TFT display, wide format (1024x600), typ. 450 cd/m²
 Capacitive multi-touch screen, glass 1.8 mm thick
 Glass front resides in milled aluminium frame (with end caps)
 Processor ARM Cortex A53, i.MX8Mmini quad-core CPU, 4x 1.6 GHz
 Chromium-based HTML5 Web Browser
 Housing: aluminium at front (IP65), stainless steel at back (IP20)
 Power supply 24 VDC ± 20%



Vico MT 1027 WEB

677 810 11

Web terminal with multi-touch screen
 10.1-inch TFT display, wide format (1280x800), typ. 420 cd/m²
 Capacitive multi-touch screen, glass 1.1 mm thick
 Glass front resides in milled aluminium frame (with end caps)
 Processor ARM Cortex A53, i.MX8Mmini quad-core CPU, 4x 1.6 GHz
 Chromium-based HTML5 Web Browser
 Housing: aluminium at front (IP65), stainless steel at back (IP20)
 Power supply 24 VDC ± 20%

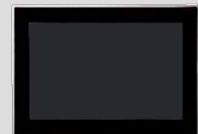

Vico MT 1527 WEB

677 810 31

Web terminal with multi-touch screen
 15.6-inch TFT display, wide format (1366x768), typ. 350 cd/m²
 Capacitive multi-touch screen, glass 1.8 mm thick
 Glass front resides in milled aluminium frame (with end caps)
 Processor ARM Cortex A53, i.MX8Mmini quad-core CPU, 4x 1.6 GHz
 Chromium-based HTML5 Web Browser
 Housing: aluminium at front (IP65), stainless steel at back (IP20)
 Power supply 24 VDC ± 20%

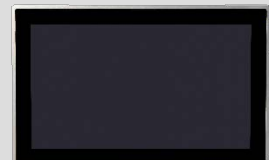

6.6.2 Accessories

Kendrion Kuhnke Automation GmbH
Industrial Control Systems

Lütjenburger Str. 101
D-23714 Malente

Tel.: +49 4523 402 0
Fax: +49 4523 402 201

sales-ics@kendrion.com
www.kendrion.com