



WE MAGNETISE THE WORLD



Locking Line

Electromagnetic Locking Systems



INDUSTRIAL MAGNETIC SYSTEMS

BINDER

We develop solutions!

Kendrion develops, manufactures and markets high-quality electromagnetic and mechatronic systems and components for industrial and automotive applications. For over a century we have been engineering precision parts for the world's leading innovators in passenger cars, commercial vehicles and industrial applications.

As a leading technology pioneer, Kendrion invents, designs and manufactures complex components and customised systems as well as local solutions on demand. Committed to the engineering challenges of tomorrow, taking responsibility for how we source, manufacture and conduct business is embedded into our culture of innovation. Rooted in Germany and headquartered in the Netherlands, our expertise extends across Europe to the Americas and Asia. Created with passion and engineered with precision.

In the business unit **Industrial Magnetic Systems (IMS)** the focus lies on electromagnetic actuators and mechatronic assemblies for applications in power engineering, safety engineering, machine building, automation technology and other industries. With the experience of our traditional brands Binder, Neue Hahn Magnet and Thoma Magnettechnik we are successful in our markets as an industry expert with a high technological competence.

We offer you both customer-specific and standardised products. Our assemblies are based on powerful and reliable single-stroke, holding, locking, spreader, control, rotary, vibratory solenoids and solenoid valves.

We always think in terms of solutions.

Our strength lies in new developments for our customers. Our engineers are specialists for innovative products with optimum technical properties. Furthermore, we develop mechanical assemblies, modern drive electronics and sensor systems to your requirements.

Our products are manufactured in Germany at the parent companies Donaueschingen and Engelswies as well as in the USA, China and Romania. This ensures efficient project management and a needs-oriented delivery for our internationally operating customers.

By means of segmented production areas we can implement both small quantities and large series with an optimum degree of automation.

We guarantee top quality.

All products are tested and developed in compliance with the norm DIN VDE 0580 for electromagnetic devices and components or according to industry-specific standards of our customers. In many cases our products are tested and certified by external associations, among others according to the CSA, VdS and ATEX guidelines. Our quality management system is certified according to DIN EN ISO 9001, and our environmental management system fulfils the norm ISO 14001.

With our subsidiaries in Austria, Italy, the USA, China and our worldwide distribution network we are your ideal partner on site.

Kendrion – We magnetise the world

www.kendrion.com

Locking Line

Single-stroke solenoids of the Kendrion Locking Line are **locking units** specially designed for use in safety devices. With these solenoids special attention has been paid to compact design, long lifetime and high lateral force load-bearing capacity.

Electromagnetic locking units are used in safety devices of machines and all types of automation equipment and as direct function in sequence controls. Furthermore, the compact variants are suitable for the safe locking of doors, cabinets and drawers.

Single-stroke solenoids are positive locking devices; in their function as locking units two different types are distinguished:

- **Currentless locking (CL):** spring force keeps bolt in locking position
- **Currentless unlocking (CU):** spring force keeps bolt open, in energized state the bolt is in locking position
- **Bistable operation (BI):** open and locked bolt position currentless, power supply for switching operation

Depending on the design a wide range of requirements can be met, including special demands of accident prevention regulations. In order to monitor the function micro-switches resp. Hall sensors providing feedback on the bolt position can be integrated in the device.

To increase the lateral force load-bearing capacity the solenoid armatures and locking bolts are installed in maintenance-free bearings with high resistance to wear. The locking bolts themselves are largely made of stainless steel.

Overview of the technical details of our locking single-stroke solenoids

Nominal voltage	24 V DC*
Duty cycle [%]	100 **
Bolt stroke [mm]	3 - 15
Locking bolt Ø [mm]	4 - 18
Locking force [N]	up to 50
Radial force [N]	up to 3000
Protection class	acc. IEC 60529
Thermal class	F
*other voltages on request	
**duty cycle LLB 25%	

Further positive lockings can be realized by **rotary solenoids**. Depending on the requirement space and cost savings can be achieved by twist locks. (Page 15)

Lockings realized by **holding solenoids** rank among non-positive lockings.

Please find examples of devices on page 14 of this catalogue.

Further holding solenoids are shown in our catalogue Industrial Line.

The products are manufactured and tested acc. DIN VDE 0580/07.2000. Design subject to change.

Bistable Locking Solenoid LLB

The electromagnetic locking LLB is a universally applicable system which is also ideal for mobile applications. The complete locking unit is based on a bistable electromagnet which can be operated by a power supply or a battery.

The locking bolt is kept in open state by means of a return spring. When power is supplied the magnet releases and locks by extending the bolt. By the force of a permanent magnet the locking bolt is kept currentless in open state. Thus, the solenoid saves up to 95% of energy compared with conventional single-stroke solenoids.

The bolt reliably bears lateral forces of 1,000N with a life-time of at least 80,000 switchings. The functionality of the locking can safely be monitored by sensors detecting the end position.



Excels by

- High energy efficiency
- Battery operation possible
- Compact and economic design



Technical data

Designation	LLB 025
Dimensions (LxWxH) [mm]	71.5 x 25 x 28
Stroke [mm]	7
Supply voltages	between 6 and 50 V DC (optional lithium block battery 9V/1200mA)
Design	Bistable (change of position by polarity reversal) Lateral and front installation: 4xM3
Duty cycle [%]	25 %
Power output [W]	6.4 W
Protection class	IP40
Holding force	50 N (permanent magnet)
Lateral force on bolt	1,000 N with front installation, 500 N with lateral installation (locking / unlocking only without lateral force / friction)
Sensor (optional)	Minus switching, 5-30V max. 30mA

Options for adjustment

- Hall sensor for one- and two-sided position detection (retrofitting possible)
- Rotation lock of bolt possible
- Extension of locking bolt via thread as supplied by customer
- Electric connection configurable
- Optional shot-bolt function: snap function with 45° inclination via torsion-free locking bolt → unit can be locked without power supply (current pulse for unlocking only)



Other stroke, voltage or installation variants on request
+49 771 8009 3770 or sales-ims@kendrion.com

Dimension drawing

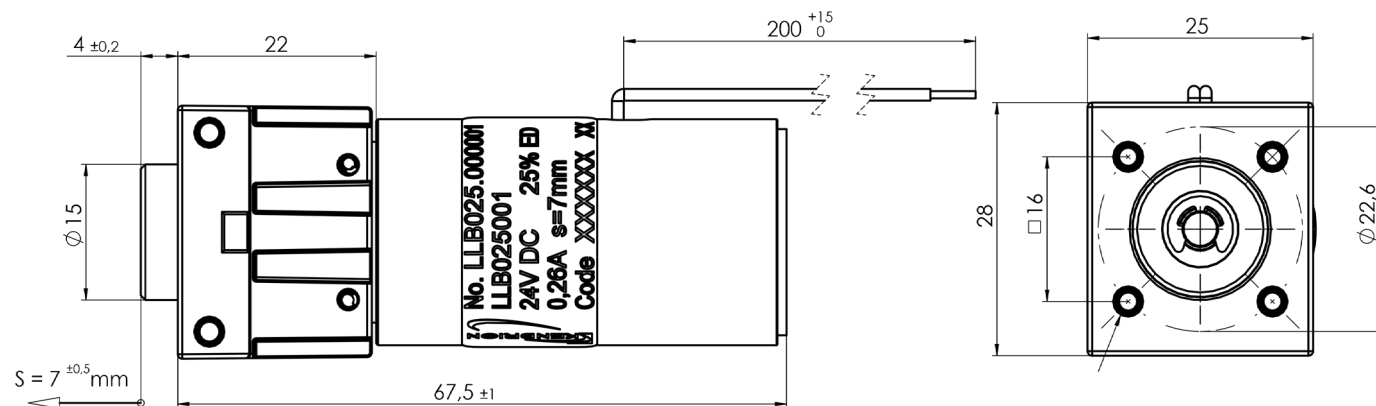

High Performance Single-Stroke Solenoid LHP-Locking

The square locking solenoid LHP-Locking is based on the high performance single-stroke solenoid LHP of the Kendrion High Performance Line. The LHP series excels by dynamic features such as shorter reaction times and higher forces.

With this single-stroke locking solenoid the locking movement takes place from stroke starting position to stroke end position, while the armature reset is effected by an integrated return spring.

The single-stroke solenoid of the LHP locking is extended by a flange which allows a separate bearing of the locking bolt, thus ensuring a high lateral force load-bearing capacity.

The installation is made by a bolt circle at the flange side.

Excels by

- Compact design
- Cost optimization

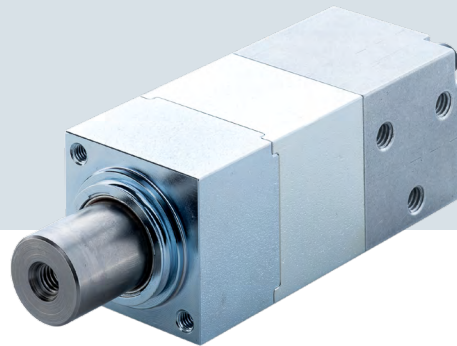

Accessories

- Plug connectors with or without rectifier
- Fork head with or without ES-bolt

Dimension drawing

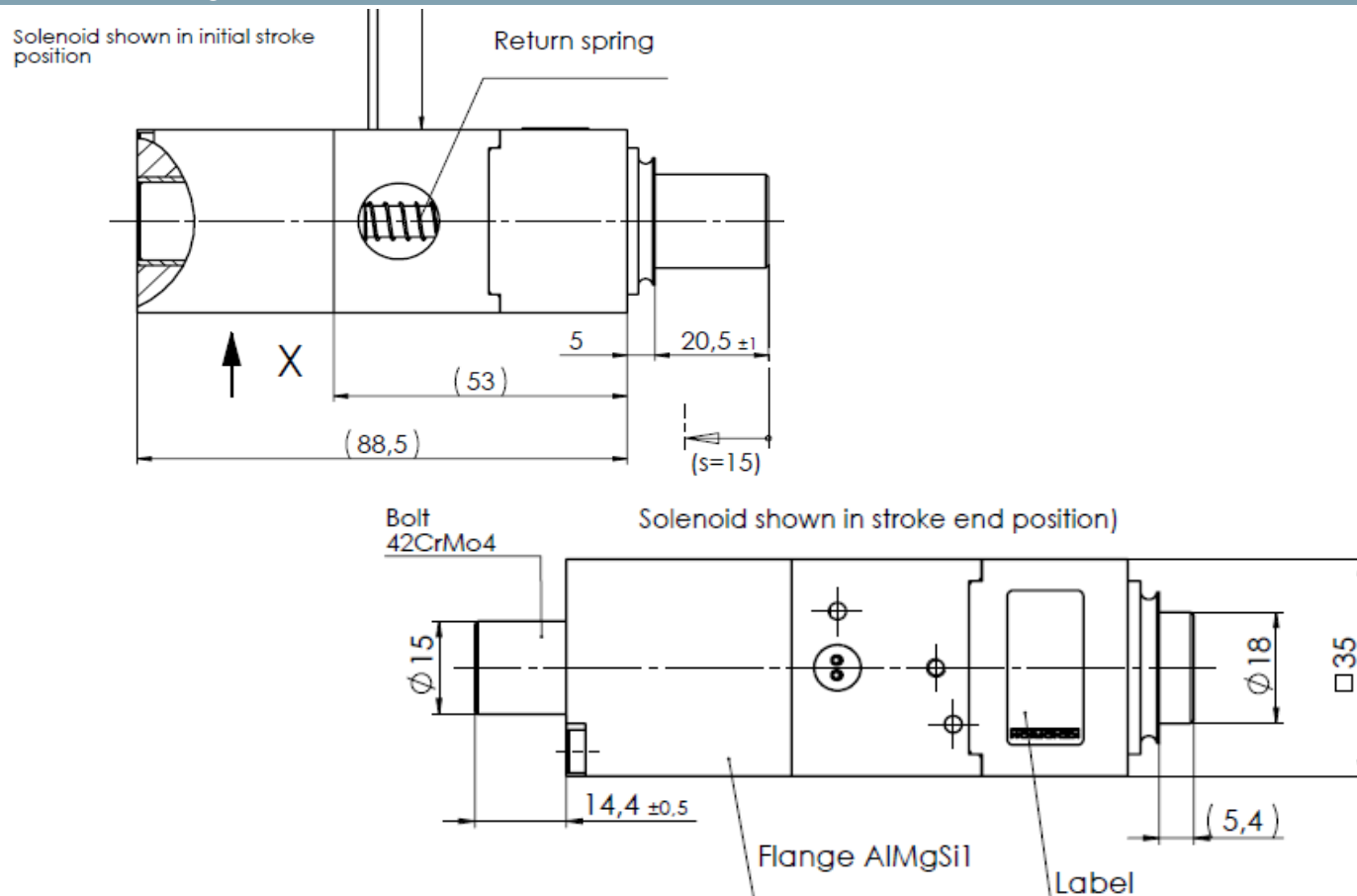

Technical data

Designation	LHP0350284
Dimensions (LxWxH) [mm]	114 x 35 x 35
Diameter locking bolt [mm]	15
Stroke [mm]	15
Supply voltage	24V DC
Duty cycle [%]	100% ED
Power output [W]	14.1
Protection class device	IP40
Force [N]	7.8
Protection class connection	IP00 (free leads); optional: IP65 (connection plug)
Lateral force on bolt [N]	3,000



Other stroke, voltage or installation variants on request
+49 771 8009 3770 or sales-ims@kendrion.com

Stroke Force Curves

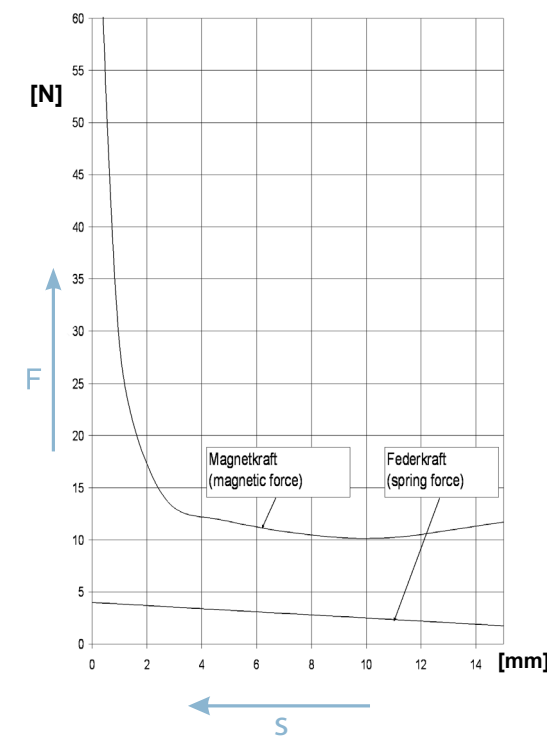

Locking Solenoids Type LLV

With the electromagnetic locking unit LLV the stroke movement takes place from stroke starting position to stroke end position (active direction of movement), while the armature reset is achieved by an integrated spring force (passive direction of movement).

Depending on the requirement two types of solenoids are available.

1. **Currentless locking (CL):** spring force keeps bolt in locking position.
2. **Currentless unlocking (CU):** spring force keeps bolt open, locked when energized.

Solenoid armatures and locking bolts are kept separate in maintenance-free bearings. The locking bolt is made of non-corrosive and non-magnetic stainless steel. The micro-switch is directly installed in the locking housing and signals the respective position of the locking bolt approx. 0.5 mm to 1 mm after leaving the stroke starting position resp. before reaching the stroke end position.

Depending on the type of device both lateral and/or front installation via thread borings is possible. Matching connector plugs for the different types of the LLV-series are available.

All products are manufactured and tested acc. DIN VDE 0580/07.2000. Design subject to change.

Technical data

Designation	LLV040001 (CU) LLV040002 (CL)	LLV050060 (CU) LLV050058 (CL)	LLV050070 (CU) LLV050081 (CL)	LLV050080 (CL)	LLV060076 (CL)
Dimensions (LxWxH) [mm]	121 x 40 x 40	148 x 50 x 50	148 x 50 x 50	171 x 50 x 50	204 x 80 x 60
Diameter locking bolt [mm]	10	14	14	14	15
Stroke [mm]	8	10	10	10	15
Supply voltage [V]	24	24	24	24	24
Duty cycle [%]	100	100	100	100	100
Power output [W]	12.8	18.3	18.3	18.3	30
Protection class	IP54	IP64	IP64	IP64	IP64
Force [N]	5	7	10	7	12
Lateral force [N]	1,200	3,000	3,000	3,000	4,000
Signal transmitter	Stroke starting and end	Stroke starting and end	Stroke starting	Stroke starting and end	Stroke starting and end
Emergency unlocking	no	no	no	manual	manual



Other stroke, voltage or installation variants on request
+49 771 8009 3770 or sales-ims@kendrion.com

Excels by

Available in high protection class

Integrated feedback of locking function

High lateral force load-bearing capacity

LLV040001 (EMV 4001) / LLV040002 (EMV 4002)

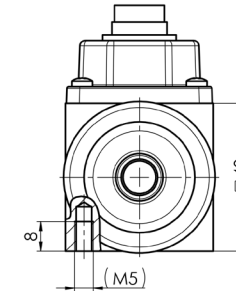

Operating principle:
Currentless unlocking (CU)
Currentless locking (CL)

Dimension drawing

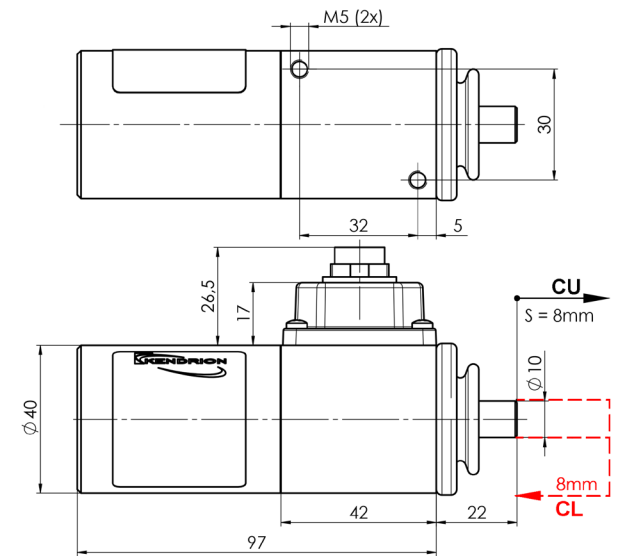

LLV050060 (EMV 5060) / LLV050058 (EMV 5058)

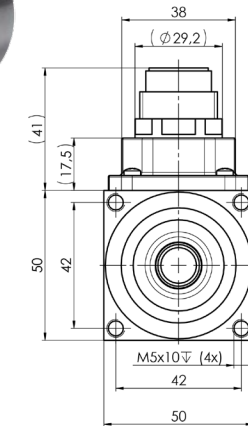

Operating principle:
Currentless unlocking (CU)
Currentless locking (CL)

Dimension drawing

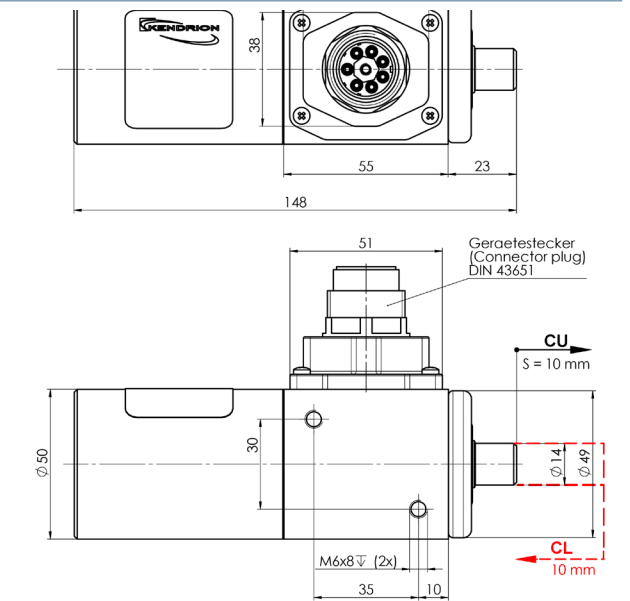

LLV050070 (EMV 5070) / LLV050081 (EMV 5081)

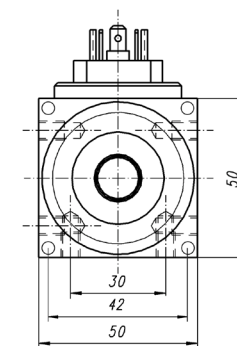
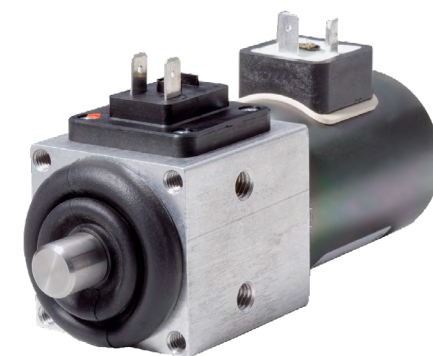

Operating principle:
Currentless unlocking (CU)
Currentless locking (CL)

Dimension drawing

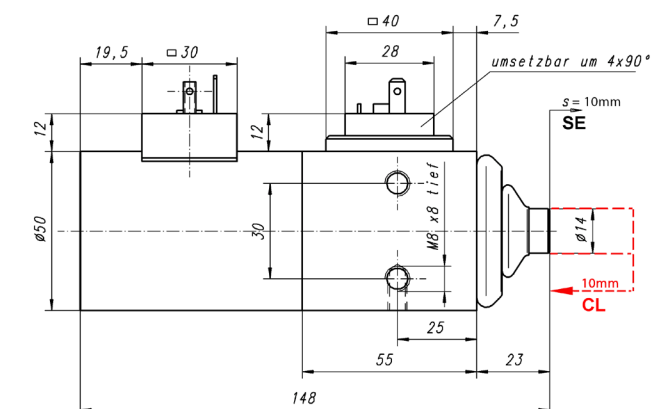

Values in brackets = old product designation

LLV050080 (EMV 5080)

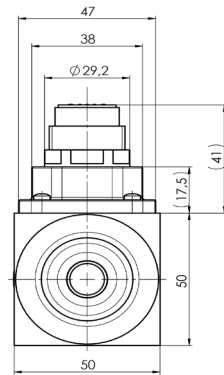

Dimension drawing

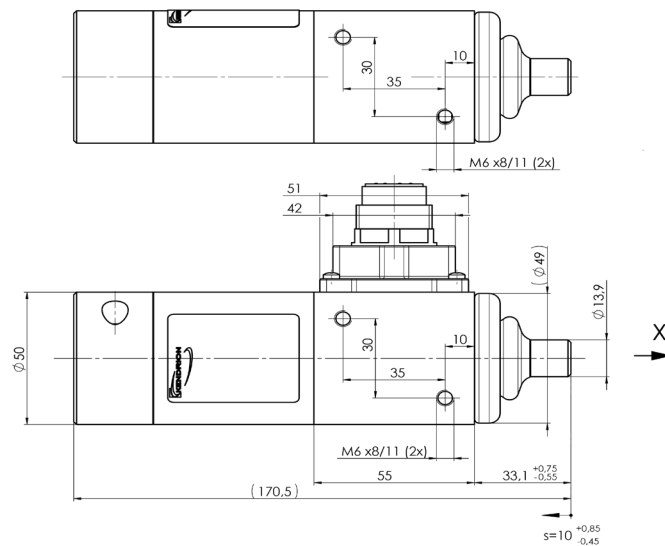

LLV060076 (EMV 6076)



Rundsteckdose
(Round electrical outlet)
RSG 6 (Art.Nr.3141053)
gehört nicht zum Lieferumfang
(be not part of the extent of supply)

Rundsteckverbinder
(round connector)
N 6 R AM 3 7-polig
nach DIN 43651

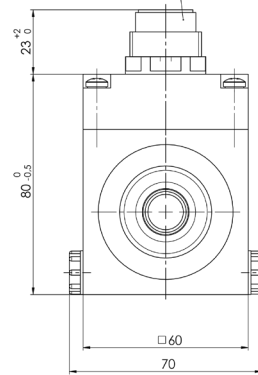

Dimension drawing

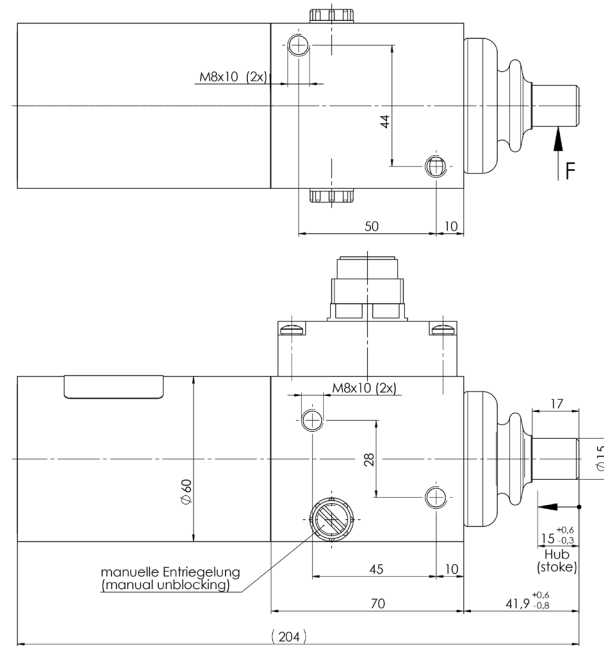

Values in brackets = old product designation

Locking Solenoids Type LLV-Compact

These locking solenoids are preferably used as safety elements with doors or similar closures in safety and fire protection engineering, ventilation and air-conditioning systems and in property protection.

Depending on the type the locking is achieved by energizing the solenoid (working current principle) or currentless by spring force (closed current principle).

The extended position of the locking bolt is indicated by a built-in micro-switch (Umax 250 V DC or with AC via integrated rectifier).

Excels by

Both DC and AC operation possible



Accessories

Counter bearing



Technical data

Type	Standard nominal voltage	Length x Width x Height [mm]	Stroke [mm]	Locking bolt [mm]	Radial force [N]	Duty cycle [%]	Function (currentless)	Signal indicator	Emergency unlocking
LLV055001	24 V DC	175 x 80 x 57	12	16	1500	100	locked	stroke end	no
LLV055002	24 V DC	175 x 80 x 57	12	16	1500	100	unlocked	stroke start	no
LLV055003	230 V AC	175 x 80 x 57	12	16	1500	100	locked	stroke end	no
LLV055004	230 V AC	175 x 80 x 57	12	16	1500	100	unlocked	stroke start	no

Dimension drawing

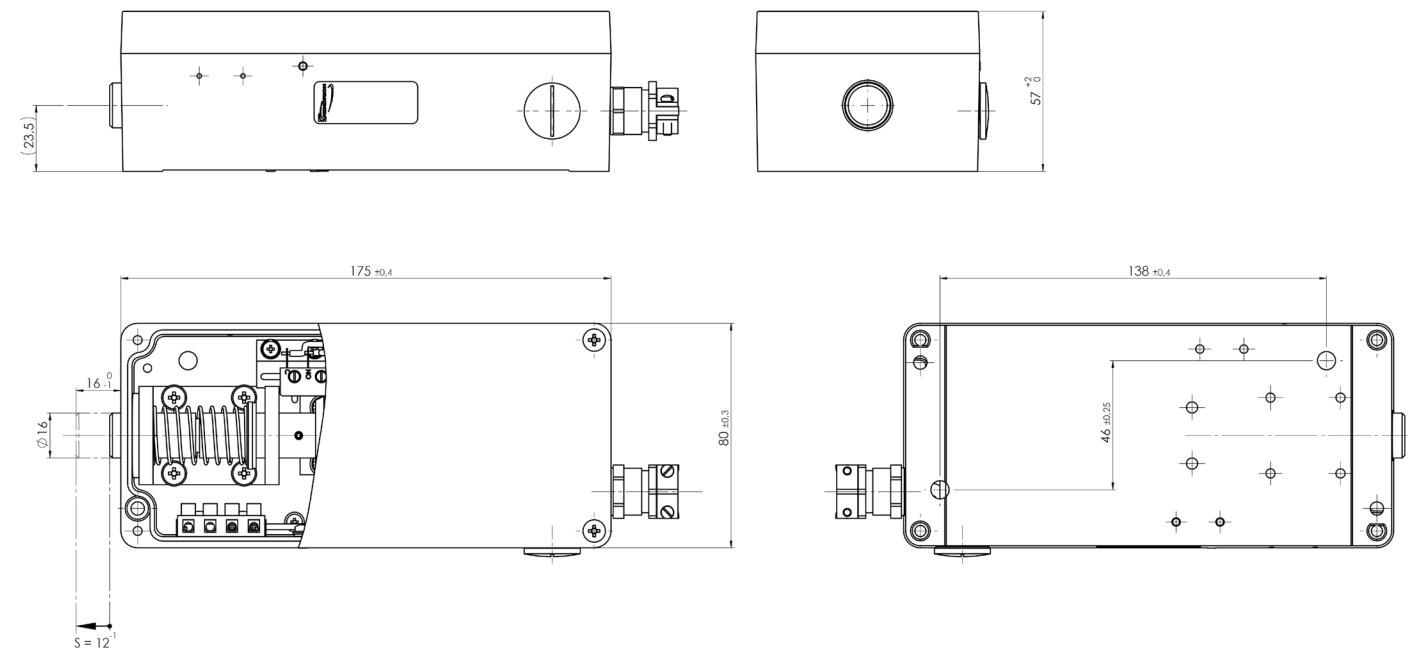

Plug Connectors

Attuned to our product portfolio Kendrion offers different plug connectors for the locking solenoids of the LLV-series. Below you find an overview of the products and the matching plug connectors.



Technical data

Locking solenoid	Connector	Order no. plug/socket
LLV040002	Connector 510-00010	510-00010
LLV050058	Connector RSG 6	3141053*
LLV050060	Connector RSG 6	3141053*
LLV050070	Valve connector Type A / Type B**	3141046 / 430006
LLV050080	Connector RSG 6	3141053*
LLV050081	Valve connector Type A / Type B**	3141046 / 430006
LLV060076	Connector RSG 6	3141053*

* incl. 7 socket contacts art.no. 3141094

** Valve connector Type B also available with bridge rectifier (230 VAC /2A DC) (430001)

Type A



Dimension Drawing

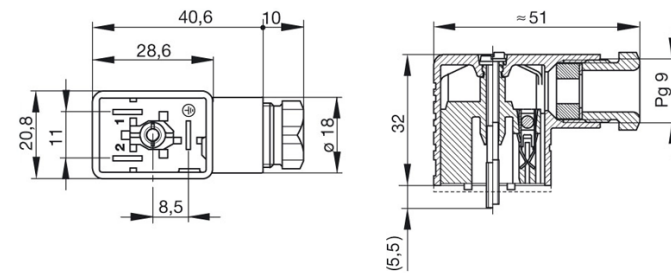

Type B



Dimension Drawing

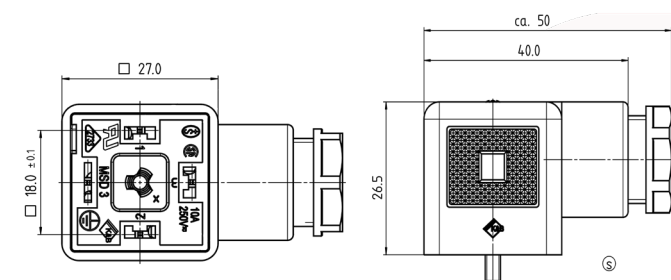

RSG6



Dimension Drawing

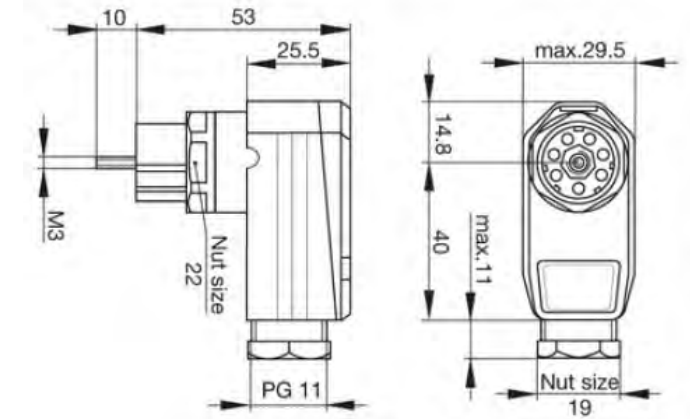

WSK6



Dimension Drawing

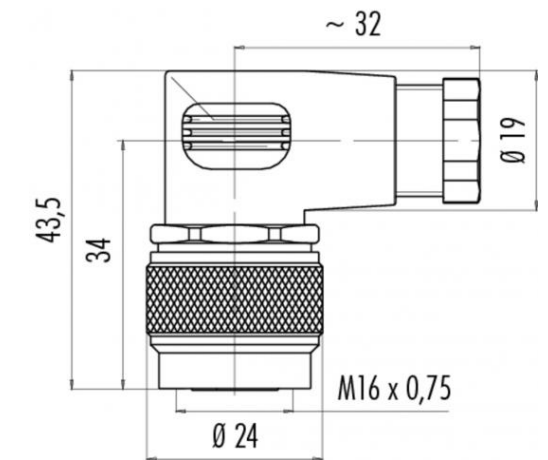

GDSB211



Dimension Drawing

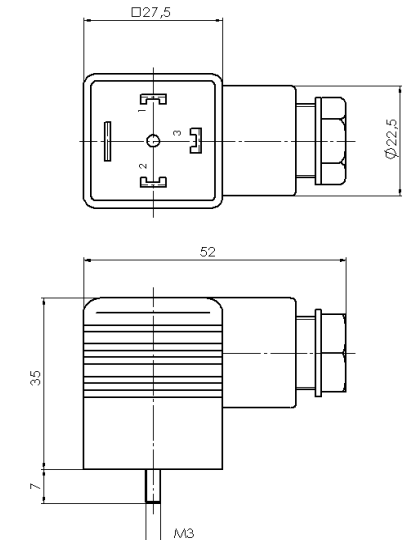

Holding Solenoids of the Industrial Line

The DC holding solenoids of the Industrial Line are divided into two different designs and two different variants. The solenoids are available in round or rectangular design resp. as “electro-holding solenoids” or “permanent electro-holding solenoids”.

Electro-holding solenoids are pot magnets and consist of a magnet housing and a DC-excited coil. The magnetic circuit which is open in energized state allows to hold ferromagnetic workpieces.

Permanent electro-holding solenoids consist of a permanent magnetic holding system to hold ferromagnetic workpieces. The additional excitation coil serves to neutralize the permanent magnetic field at the holding surface.

Advantages

- High holding force with low power consumption
- Cost-efficient
- Simple, compact solution
- Wide range of connection options
- Frictional locking, to be realized with simple components

Technical data

Type	10 33106A00	GT063B001	GT250B001	10 31001A1	01 32015B00
Diameter x Height [mm]	56 x 13	63 x 30	250 x 80	101,5 x 32 x 31	150 x 63
Max. holding force [N]	750	1.000	30.000	880	3.500
Nominal output [W]	7.1	7.9	90	6.5	40.5
Thickness of armature plate [mm]	4	7	29	8	12.5
Thread x Depth [mm]	Bore Ø 6,6	M8 x 12	M24 x 36	M6 x 10	M16 x 16
Length of cable/strand [mm]	300	200	300	8.5	300
Weight [kg]	0.20	0.60	26	0.60	6.40
CL / CU	currentless unlocked	currentless unlocked	currentless unlocked	currentless unlocked	currentless locked

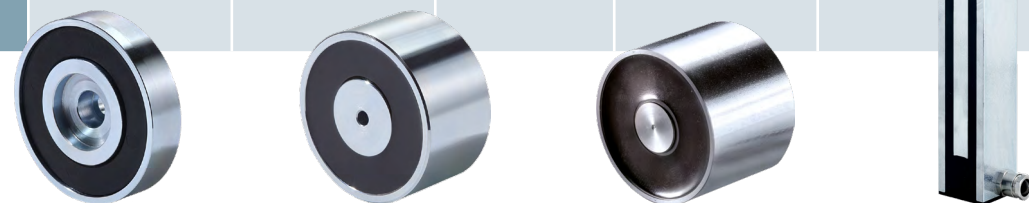

Please find a complete overview of our holding solenoids in our catalogue Industrial Line

Fields of Application

- Safety engineering**
- Automation engineering**
- Machine building**

Rotary Solenoid CDR

The CDR combines compact design and short switching times with intelligent solenoid design. Due to its compact design the CDR is the ideal solution for a variety of applications. Not least due to the integrated sensors responsible for the functional control the transfer of the rotary movement to the shaft is highly reliable.

The rotary solenoid excels by a feasible switching time of 10 to 30 milliseconds and a rotation angle of up to 150°. Size, functionality and technical parameters can be customized to your demand.

In addition, you save up to 80% of energy due to the bistable design of the solenoid. As opposed to conventional rotary solenoids the CDR only requires current for switching and is kept currentless in rest position.



Excels by

- Simple design, therefore very cost-efficient**
- High energy efficiency (current only during switching time)**
- Low wear due to ball bearing**
Hall sensors can be integrated for small additional charge
- Modular design, therefore easy to adapt**



Options for adjustment

- Hall sensor for recognition of end position, one or two-sided
- Muted stop can be integrated
- Mono- und bistable design possible
- Other voltages possible
- Duty cycle of up to 50% possible
- Higher protection class can be realized
- Rotation angle from 20 to 150° can be

The ideal choice for your application

- There is a multitude of applications where the use of a rotary solenoid (and not of a linear actuator) simplifies the usage.
- Fewer components
 - Detection of end position
 - Increased process safety

Technical data of the standard type CDR030

Rotation angle	90°
Supply voltage	24 V DC
Type	Bistable (Change of position by polarity reversal) Free strands (200mm)
Duty cycle	15 %
Output power	30 W
Torque (energized)	3.4 – 7.8 Ncm
Holding torque (de-energized)	3.2 Ncm
Protection class	IP30
Ambient temperature	-10 to +40°C
Hall sensor (optional)	minus switching, 5-30 V DC, max 30 mA

Possible applications

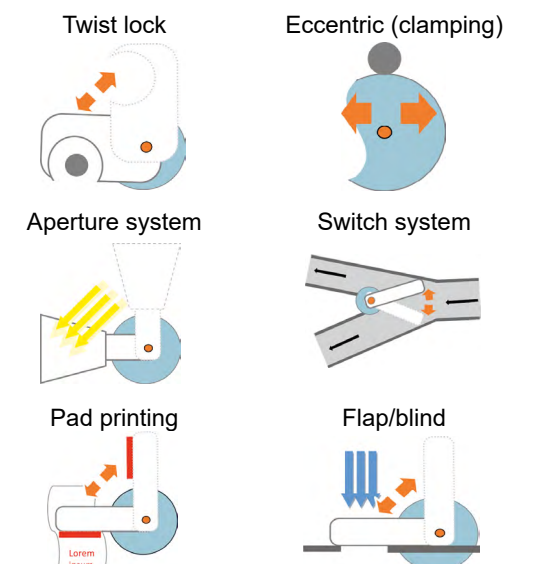

Overview of Catalogue

Linear Solenoids

Classic Line	High Performance Line	High Power Line	Control Power Line	Elevator Line	ATEX Line	Locking Line	System Line
<ul style="list-style-type: none"> single-stroke solenoids compact design individual fixing mono- and bistable version 	<ul style="list-style-type: none"> square single-stroke solenoids high force with small installation space modular system short pull-in times 	<ul style="list-style-type: none"> round single-stroke solenoids high forces and stroke travels short switching times also reversible solenoids 	<ul style="list-style-type: none"> control solenoids extremely fast switching short strokes precise switching 	<ul style="list-style-type: none"> spreader solenoids especially designed for elevator brakes extremely high forces any mounting position 	<ul style="list-style-type: none"> explosion-proof solenoids prevent the occurrence of sparks and light arcs dynamic and reliable switching 	<ul style="list-style-type: none"> locking solenoids high transverse forces integrated feedback of locking function compact design 	<ul style="list-style-type: none"> operated by AC extremely short activation times very high pull-in forces

Electro Holding Magnets

- | Hahn CQ ^{Line} | Industrial Line |
|---|---|
| <ul style="list-style-type: none"> door holding magnet design and functionality VdS, CE, EN 1155, EN 14637 tested great variety | <ul style="list-style-type: none"> industrial holding magnets high holding force with low power consumption compact design variable connections |

Oscillating Solenoids

- vibratory solenoids
- wide product range for transportation of bulk material
- low wear and tear
- compact design

Custom Solutions

- Rotary solenoids
- Assemblies
- Customer-specific solutions

Please contact us for special or customer-specific solutions.

Kendrion (Donaueschingen/Engelswies) GmbH
 Industrial Magnetic Systems
 Sales Team Donaueschingen and Engelswies
 Tel.: +49 771 8009 3770
 Mail: sales-ims@kendrion.com



WE MAGNETISE THE WORLD

If you do not find what you are looking for, please feel free to contact us!
We will find the best solution for you.

Germany : Headquarters

Kendrion (Donaueschingen/Engelswies) GmbH
August-Fischbach-Straße 1
78166 Donaueschingen
Telefon: +49 771 8009 0
Telefax: +49 771 8009 3634
sales-ims@kendrion.com

Germany: Headquarters

Kendrion (Donaueschingen/Engelswies) GmbH
Hauptstraße 6
72514 Inzigkofen-Engelswies
Telefon: +49 7575 208 0
Telefax: +49 7575 208 3190
sales-ims@kendrion.com

For further contacts please refer to www.kendrion.com

